

Keithley Instruments, Inc.  
 28775 Aurora Road  
 Cleveland, Ohio 44139  
 1-888-KEITHLEY  
 www.keithley.com

## System SourceMeter® Specifications

### 1. SPECIFICATION CONDITIONS

This document contains specifications and supplemental information for the Models 2601A and 2602A System SourceMeters®. Specifications are the standards against which the Models 2601A and 2602A are tested. Upon leaving the factory the 2601A and 2602A meet these specifications. Supplemental and typical values are non-warranted, apply at 23°C, and are provided solely as useful information.

Accuracy specifications are applicable for both Normal and High Capacitance Modes.

The source and measurement accuracies are specified at the SourceMeters® CHANNEL A (2601A and 2602A) or SourceMeters® CHANNEL B (2602A) terminals under the following conditions:

1. 23°C ± 5°C, < 70% relative humidity.
2. After two-hour warm-up.
3. Speed normal (1 NPLC).
4. A/D auto-zero enabled.
5. Remote sense operation or properly zeroed local operation.
6. Calibration period: one year.

### 2. SOURCE SPECIFICATIONS

#### VOLTAGE SOURCE SPECIFICATIONS

Specifications Category	Specifications			
	RANGE	PROGRAMMING RESOLUTION	ACCURACY (1 Year) 23°C ± 5°C ± (% rdg. + volts)	TYPICAL NOISE (peak-peak) 0.1 Hz–10 Hz
Voltage Programming Accuracy <sup>1</sup>	100.000 mV	5 µV	0.02% + 250 µV	20 µV
	1.00000 V	50 µV	0.02% + 400 µV	50 µV
	6.00000 V	50 µV	0.02% + 1.8 mV	100 µV
	40.0000 V	500 µV	0.02% + 12 mV	500 µV
Temperature Coefficient <sup>2</sup>	± (0.15 × accuracy specification)/°C • For temperatures (0°–18°C & 28°–50°C)			
Maximum Output Power and Source/Sink Limits <sup>3</sup>	40.4 W per channel maximum. • ± 40.4 V @ ± 1.0 A • ± 6.06 V @ ± 3.0 A • Four-quadrant source or sink operation.			
Voltage Regulation	Line: 0.01% of range Load: ± (0.01% of range + 100 µV).			
Noise 10 Hz – 20 MHz	< 20 mV peak-peak (typical), < 3 mV RMS (typical) • 6 V range			

<sup>1</sup> Add 50 µV to source accuracy specifications per volt of HI lead drop.

<sup>2</sup> High Capacitance Mode accuracy is applicable at 23°C ± 5°C only.

<sup>3</sup> Full power source operation regardless of load to 30°C ambient. Above 30°C and/or power sink operation, refer to “Operating Boundaries” in the Series 2600A Reference Manual for additional power derating information.

Specifications are subject to change without notice.

Keithley Instruments, Inc.  
 28775 Aurora Road  
 Cleveland, Ohio 44139  
 1-888-KEITHLEY  
 www.keithley.com

**System SourceMeter® Specifications**

Specifications Category	Specifications
Current Limit/Compliance <sup>4</sup>	Bipolar current limit (compliance) set with single value. Minimum value is 10 nA. Accuracy is the same as current source.
Overshoot	< ± (0.1% + 10 mV) (typical) <ul style="list-style-type: none"> <li>• Step size = 10% to 90% of range, resistive load, maximum current limit/compliance.</li> </ul>
Guard Offset Voltage	< 4 mV <ul style="list-style-type: none"> <li>• Current &lt; 10 mA</li> </ul>

**CURRENT SOURCE SPECIFICATIONS**

Specifications Category	Specifications			
Current Programming Accuracy	RANGE	PROGRAMMING RESOLUTION	ACCURACY (1 Year) 23°C ± 5°C ± (% rdg. + amps)	TYPICAL NOISE (peak-peak) 0.1 Hz–10 Hz
	100.000 nA	1 pA	0.06% + 100 pA	5 pA
	1.00000 µA	10 pA	0.03% + 800 pA	25 pA
	10.0000 µA	100 pA	0.03% + 5 nA	60 pA
	100.000 µA	1 nA	0.03% + 60 nA	3 nA
	1.00000 mA	10 nA	0.03% + 300 nA	6 nA
	10.0000 mA	100 nA	0.03% + 6 µA	200 nA
	100.000 mA	1 µA	0.03% + 30 µA	600 nA
	1.00000 A <sup>5</sup>	10 µA	0.05% + 1.8 mA	70 µA
	3.00000 A <sup>5</sup>	10 µA	0.06% + 4 mA	150 µA
10.0000 A <sup>5,6</sup>	100 µA	0.5% + 40 mA (typical)		
Temperature Coefficient <sup>7</sup>	± (0.15 × accuracy specification)/°C <ul style="list-style-type: none"> <li>• For temperatures (0° – 18°C &amp; 28° – 50°C)</li> </ul>			

<sup>4</sup> For sink mode operation (quadrants II and IV), add 0.06% of limit range to the corresponding current limit accuracy specifications. Specifications apply with sink mode enabled.

<sup>5</sup> Full power source operation regardless of load to 30°C ambient. Above 30°C and/or power sink operation, refer to “Operating Boundaries” in the Series 2600A Reference Manual for additional power derating information.

<sup>6</sup> 10A range accessible only in pulse mode.

<sup>7</sup> High Capacitance Mode accuracy is applicable at 23°C ± 5°C only.

Specifications are subject to change without notice.

Keithley Instruments, Inc.  
 28775 Aurora Road  
 Cleveland, Ohio 44139  
 1-888-KEITHLEY  
 www.keithley.com

**System SourceMeter® Specifications**

Specifications Category	Specifications
Maximum Output Power and Source/Sink Limits <sup>8</sup>	40.4 W per channel maximum. <ul style="list-style-type: none"> <li>• ± 1.01 A @ ± 40 V</li> <li>• ± 3.03 A @ ± 6 V</li> <li>• Four-quadrant source or sink operation.</li> </ul>
Current Regulation	Line: 0.01% of range Load: ± (0.01% of range + 100 pA).
Voltage Limit/Compliance <sup>9</sup>	Bipolar voltage limit (compliance) set with single value. Minimum value is 10 mV. Accuracy is the same as voltage source.
Overshoot	< ± 0.1% (typical) <ul style="list-style-type: none"> <li>• step size = 10% to 90% of range, resistive load</li> <li>• See CURRENT SOURCE OUTPUT SETTLING TIME for additional test conditions</li> </ul>

**ADDITIONAL SOURCE SPECIFICATIONS**

Specifications Category	Specifications	
Transient Response Time	< 70 µs for the output to recover to within 0.1% for a 10% to 90% step change in load.	
Voltage Source Output Settling Time	Time required to reach within 0.1% of final value after source level command is processed on a fixed range.	
	<b>Range</b>	<b>Settling Time</b>
	100 mV	< 50 µs (typical)
	1 V	< 50 µs (typical)
	6 V	< 110 µs (typical)
	40 V <sup>10</sup>	< 150 µs (typical)
Current Source Output Settling Time	Time required to reach within 0.1% of final value after source level command is processed on a fixed range. <ul style="list-style-type: none"> <li>• Values below for I<sub>out</sub> × R<sub>load</sub> = 1 V unless noted</li> </ul>	
	<b>Current Range</b>	<b>Settling Time</b>
	3 A	< 80 µs (typical) (Current less than 2.5 A, R <sub>load</sub> > 2 Ω)
	1 A – 10 mA	< 80 µs (typical) (R <sub>load</sub> > 6 Ω)
	1 mA	< 100 µs (typical)
	100 µA	< 150 µs (typical)
	10 µA	< 500 µs (typical)
	1 µA	< 2 ms (typical)
100 nA	< 20 ms (typical)	

<sup>8</sup> Full power source operation regardless of load to 30°C ambient. Above 30°C and/or power sink operation, refer to "Operating Boundaries" in the Series 2600A Reference Manual for additional power derating information.

<sup>9</sup> For sink mode operation (quadrants II and IV), add 10% of compliance range and ±0.02% of limit setting to corresponding voltage source specification. For 100mV range add an additional 60mV of uncertainty.

<sup>10</sup> Add 150 µs when measuring on the 1A range.

Keithley Instruments, Inc.  
 28775 Aurora Road  
 Cleveland, Ohio 44139  
 1-888-KEITHLEY  
 www.keithley.com

**System SourceMeter® Specifications**

Specifications Category	Specifications
DC Floating Voltage	Output can be floated up to $\pm 250$ VDC
Remote Sense Operating Range <sup>11</sup>	Maximum voltage between HI and SENSE HI = 3 V Maximum voltage between LO and SENSE LO = 3V
Voltage Output Headroom	<b>40 V Range</b> <ul style="list-style-type: none"> <li>Maximum output voltage = 42 V – total voltage drop across source leads. (maximum 1 <math>\Omega</math> per source lead)</li> </ul> <b>6 V Range</b> <ul style="list-style-type: none"> <li>Maximum output voltage = 8 V – total voltage drop across source leads. (maximum 1 <math>\Omega</math> per source lead)</li> </ul>
Over Temperature Protection	Internally sensed temperature overload puts unit in standby mode.
Voltage Source Range Change Overshoot	< 300 mV + 0.1% of larger range (typical) <ul style="list-style-type: none"> <li>Overshoot into a 100 k<math>\Omega</math> load, 20 MHz BW</li> </ul>
Current Source Range Change Overshoot	< 5% of larger range + 300 mV/Rload (typical – With source settling set to SETTLE_SMOOTH_100NA) <ul style="list-style-type: none"> <li>See CURRENT SOURCE OUTPUT SETTLING TIME for additional test conditions.</li> </ul>

**PULSE SPECIFICATIONS**

Specifications Category	Specifications			
	Region Circled On Quadrant Diagram	Maximum Current Limit	Maximum Pulse Width <sup>12</sup>	Maximum Duty Cycle <sup>13</sup>
Pulse Specifications	1	1 A at 40 V	DC, no limit	100%
	1	3 A at 6 V	DC, no limit	100%
	2	1.5 A at 40 V	100 ms	25%
	3	5 A at 35V	4 ms	4%
	4	10 A at 20 V	1.8 ms	1%

<sup>11</sup> Add 50  $\mu$ V to source accuracy specifications per volt of HI lead drop.

<sup>12</sup> Times measured from the start of pulse to the start off-time; see figure below.

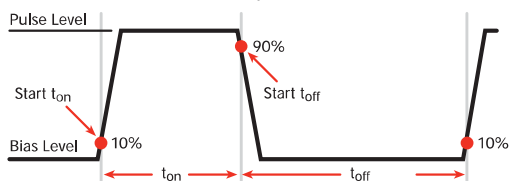

<sup>13</sup> Thermally limited in sink mode (quadrants 2 and 4) and ambient temperatures above 30°C. See power equations in the Reference Manual for more information.

Specifications are subject to change without notice.

Keithley Instruments, Inc.  
 28775 Aurora Road  
 Cleveland, Ohio 44139  
 1-888-KEITHLEY  
 www.keithley.com

### System SourceMeter® Specifications

Specifications Category	Specifications
Minimum Programmable Pulse Width <sup>14,15</sup>	100 $\mu$ s • Note: Minimum pulse width for settled source at a given I/V output and load can be longer than 100 ms.
Pulse Width Programming Resolution	1 $\mu$ s
Pulse Width Programming Accuracy <sup>15</sup>	$\pm$ 5 $\mu$ s
Pulse Width Jitter	2 $\mu$ s (typical)
Quadrant Diagram	<p>The diagram is a plot of current (A) on the y-axis versus voltage (V) on the x-axis. The y-axis ranges from -10A to +10A with major ticks every 1.5A. The x-axis ranges from -40V to +40V with major ticks every 5V. The plot is divided into four quadrants: I (top-right), II (top-left), III (bottom-left), and IV (bottom-right). A central region is shaded gray and contains a vertical red line at 0V and a horizontal red line at 0A. Four numbered circles (1, 2, 3, 4) are placed at the intersections of the red lines and the boundaries of the shaded region. Region I is the top-right area, II is the top-left, III is the bottom-left, and IV is the bottom-right. The shaded region is bounded by approximately -20V to +20V on the x-axis and -5A to +5A on the y-axis.</p>

<sup>14</sup> Typical performance for minimum settled pulse widths: Typical tests were performed using remote operation, 4W sense, and best fixed measurement range. For more information on pulse scripts, see the Series 2600A Reference Manual.

Source Value	Load	Source Settling (% of range)	Min. Pulse Width
6 V	2 $\Omega$	0.2%	150 $\mu$ s
20 V	2 $\Omega$	1%	200 $\mu$ s
35 V	7 $\Omega$	0.5%	500 $\mu$ s
40 V	27 $\Omega$	0.1%	400 $\mu$ s
1.5 A	27 $\Omega$	0.1%	1.5 ms
3 A	2 $\Omega$	0.2%	150 $\mu$ s
5 A	7 $\Omega$	0.5%	500 $\mu$ s
10 A	2 $\Omega$	0.5%	200 $\mu$ s

<sup>15</sup> Times measured from the start of pulse to the start off-time; see figure below.

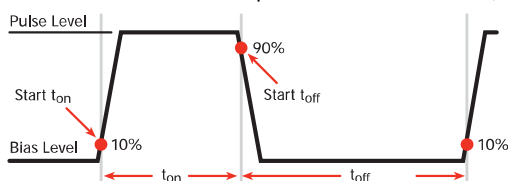

Keithley Instruments, Inc.  
 28775 Aurora Road  
 Cleveland, Ohio 44139  
 1-888-KEITHLEY  
 www.keithley.com

**System SourceMeter® Specifications**
**3. METER SPECIFICATIONS**
**VOLTAGE MEASUREMENT SPECIFICATIONS**

Specifications Category	Specifications			
Voltage Measurement Accuracy <sup>16,17</sup>	<b>RANGE</b>	<b>DISPLAY RESOLUTION<sup>18</sup></b>	<b>INPUT IMPEDANCE</b>	<b>ACCURACY (1 Year) 23°C ± 5°C ± (% rdg. + volts)</b>
	100.000 mV	1 µV	> 10 GΩ	0.015% + 150 µV
	1.00000 V	10 µV	> 10 GΩ	0.015% + 200 µV
	6.00000 V	10 µV	> 10 GΩ	0.015% + 1 mV
	40.0000 V	100 µV	> 10 GΩ	0.015% + 8 mV
Temperature Coefficient <sup>19</sup>	± (0.15 × accuracy specification)/°C • For temperatures (0°–18°C & 28°–50°C)			

<sup>16</sup> Add 50µV to source accuracy specifications per volt of HI lead drop.

<sup>17</sup> De-rate accuracy specifications for NPLC setting < 1 by increasing error term. Add appropriate % of range term using table below.

NPLC Setting	100 mV Range	1 V – 40 V Ranges	100 nA Range	1 µA – 100 mA Ranges	1 A – 3 A Ranges
0.1	0.01%	0.01%	0.01%	0.01%	0.01%
0.01	0.08 %	0.07%	0.1 %	0.05%	0.05%
0.001	0.8 %	0.6 %	1 %	0.5 %	1.1 %

<sup>18</sup> Applies when in single channel display mode.

<sup>19</sup> High Capacitance Mode accuracy is applicable for 23°C ± 5°C only.

Specifications are subject to change without notice.

Keithley Instruments, Inc.  
 28775 Aurora Road  
 Cleveland, Ohio 44139  
 1-888-KEITHLEY  
 www.keithley.com

**System SourceMeter® Specifications**
**CURRENT MEASUREMENT SPECIFICATIONS**

Specifications Category	Specifications			
Current Measurement Accuracy <sup>17</sup>	<b>RANGE</b>	<b>DISPLAY RESOLUTION<sup>20</sup></b>	<b>VOLTAGE BURDEN<sup>21</sup></b>	<b>ACCURACY (1 Year) 23°C ± 5°C ± (% rdg. + amps)</b>
	100.000 nA	1 pA	< 1 mV	0.05% + 100 pA
	1.00000 µA	10 pA	< 1 mV	0.025% + 500 pA
	10.0000 µA	100 pA	< 1 mV	0.025% + 1.5 nA
	100.000 µA	1 nA	< 1 mV	0.02% + 25 nA
	1.00000 mA	10 nA	< 1 mV	0.02% + 200 nA
	10.0000 mA	100 nA	< 1 mV	0.02% + 2.5 µA
	100.000 mA	1 µA	< 1 mV	0.02% + 20 µA
	1.00000 A	10 µA	< 1 mV	0.03% + 1.5 mA
	3.00000 A	10 µA	< 1 mV	0.05% + 3.5 mA
10.0000 <sup>22</sup> A	100 µA	< 1 mV	0.4% + 25 mA (typical)	
Current Measure <sup>23</sup> Settling Time (Time for measurement to settle after a Vstep)	Time required to reach within 0.1% of final value after source level command is processed on a fixed range. • Values below for Vout = 1 V unless noted			
	<b>Current Range</b>		<b>Settling Time</b>	
	1 mA		< 100 µs (typical)	
Temperature Coefficient <sup>24</sup>	± (0.15 × accuracy specification)/°C • For temperatures (0°–18°C & 28°–50°C)			

<sup>20</sup> Applies when in single channel display mode.

<sup>21</sup> Four-wire remote sense only and with current meter mode selected. Voltage measure set to 100 mV or 1 V range only.

<sup>22</sup> 10 A range accessible only in pulse mode.

<sup>23</sup> Compliance equal to 100 mA.

<sup>24</sup> High Capacitance Mode accuracy is applicable for 23°C ± 5°C only.

Specifications are subject to change without notice.

Keithley Instruments, Inc.  
 28775 Aurora Road  
 Cleveland, Ohio 44139  
 1-888-KEITHLEY  
 www.keithley.com

**System SourceMeter® Specifications****CONTACT CHECK**

Specifications Category	Specifications		
Contact Check Specifications <sup>25</sup>	<b>Speed</b>	<b>Maximum measurement time to memory for 60Hz (50Hz)</b>	<b>ACCURACY (1 Year) 23°C ± 5°C ± (% rdg. + ohms)</b>
	Fast	1.1 ms (1.2 ms)	5% + 10 Ω
	Medium	4.1 ms (5 ms)	5% + 1 Ω
	Slow	36 ms (42 ms)	5% + 0.3 Ω

**ADDITIONAL METER SPECIFICATIONS**

Specifications Category	Specifications	
Maximum Load Impedance	<b>Normal Mode</b> 10nF (typical)	<b>High Capacitance Mode</b> 50uF (typical)
Common Mode Voltage	250 VDC	
Common Mode Isolation	> 1 GΩ < 4500 pF	
Ovrange	101% of source range 102% of measure range	
Maximum Sense Lead Resistance	1 kΩ for rated accuracy	
Sense High Input Impedance	> 10 GΩ	

<sup>25</sup> Includes measurement of SENSE HI to HI and SENSE LO to LO contact resistances.



Keithley Instruments, Inc.  
 28775 Aurora Road  
 Cleveland, Ohio 44139  
 1-888-KEITHLEY  
 www.keithley.com

**System SourceMeter® Specifications**
**HIGH CAPACITANCE MODE<sup>26,27,28</sup>**

Specifications Category	Specifications	
Accuracy Specifications	Accuracy specifications are applicable in both Normal and High Capacitance Modes.	
Voltage Source Output Settling Time	Time required to reach within 0.1% of final value after source level command is processed on a fixed range. Current limit = 1A	
	<b>Voltage Source Range</b>	<b>Settling Time with C<sub>load</sub> = 4.7µF</b>
	100 mV	200 µs (typical)
	1 V	200 µs (typical)
	6 V	200 µs (typical)
	40 V	7 ms (typical)
Current Measure Settling Time	Time required to reach within 0.1% of final value after voltage source is stabilized on a fixed range. • Values below for Vout = 1 V unless noted	
	<b>Current Measure Range</b>	<b>Settling Time</b>
	3 A – 1 A	< 120 µs (typical) (R <sub>load</sub> > 2 Ω)
	100 mA – 10 mA	< 100 µs (typical)
	1 mA	< 3 ms (typical)
	100 µA	< 3 ms (typical)
	10 µA	< 230 ms (typical)
1 µA	< 230 ms (typical)	
Capacitor Leakage Performance Using HIGH-C scripts <sup>29</sup>	200 ms (typical) @ 50 nA Load = 5µF  10MΩ Test: 5V step & measure	
Mode Change Delay	<b>100 µA Current Range and above:</b> Delay into High Capacitance Mode: 11 ms Delay out of High Capacitance Mode: 11 ms <b>1 µA and 10 µA Current Ranges:</b> Delay into High Capacitance Mode: 250 ms Delay out of High Capacitance Mode: 11 ms	
Voltmeter Input Impedance	> 10 GΩ in parallel with 3300 pF	
Noise 10 Hz – 20 MHz	< 30 mV peak-peak (typical) • 6 V Range	

<sup>26</sup> High Capacitance Mode specifications are for DC measurements only.

<sup>27</sup> 100 nA range is not available in High Capacitance Mode.

<sup>28</sup> High Capacitance Mode utilizes locked ranges. Auto Range is disabled.

<sup>29</sup> Part of KI Factory scripts. See the reference manual for details.



Keithley Instruments, Inc.  
28775 Aurora Road  
Cleveland, Ohio 44139  
1-888-KEITHLEY  
www.keithley.com

System SourceMeter® Specifications

Specifications Category	Specifications
Voltage Source Range Change Overshoot	< 400 mV + 0.1% of larger range (typical) • Overshoot into an 100 KΩ load, 20 MHz BW

4. GENERAL

Specifications Category	Specifications
IEEE-488	IEEE Std 488.1 compliant. Supports IEEE Std 488.2 common commands and status model topology.
RS-232	Baud rates from 300bps to 115200bps. Programmable number of data bits, parity type, and flow control (RTS/CTS hardware or none). When not programmed as the active host interface, the SourceMeter can use the RS-232 interface to control other –instrumentation
Ethernet	RJ-45 connector, LXI Class C, 10/100BT, Auto MDIX
LXI Compliance	LXI Class C 1.2 <b>Total Output Trigger Response Time:</b> 245 μs min., 280 μs typ., (not specified) max. Receive LAN[0-7] Event Delay: Unknown Generate LAN[0-7] Event Delay: Unknown
Expansion Interface	The TSP-Link™ expansion interface allows TSP™ enabled instruments to trigger and communicate with each other. <b>Cable Type:</b> Category 5e or higher LAN crossover cable. 3 meters maximum between each TSP enabled instrument
USB	USB 2.0 Host Controller
Power Supply	100 V to 250 VAC, 50 Hz – 60 Hz (auto sensing), 240 VA max

Keithley Instruments, Inc.  
 28775 Aurora Road  
 Cleveland, Ohio 44139  
 1-888-KEITHLEY  
 www.keithley.com

### System SourceMeter® Specifications

Specifications Category	Specifications
<p>Digital I/O Interface</p>	<p><b>Connector:</b> 25-pin female D  <b>Input/Output Pins:</b> 14 open drain I/O bits  <b>Absolute Maximum Input Voltage:</b> 5.25 V  <b>Absolute Minimum Input Voltage:</b> - 0.25 V  <b>Maximum Logic Low Input Voltage:</b> 0.7V, +850 <math>\mu</math>A max  <b>Minimum Logic High Input Voltage:</b> 2.1V, + 570 <math>\mu</math>A  <b>Maximum Source Current (flowing out of Digital I/O bit):</b> + 960 <math>\mu</math>A  <b>Maximum Sink Current @ Maximum Logic Low Voltage (0.7V):</b> - 5.0 mA  <b>Absolute Maximum Sink Current (flowing into Digital I/O pin):</b> - 11 mA  <b>5V Power Supply Pin:</b> Limited to 250 mA, solid state fuse protected  <b>Output enable Pin:</b>          Active high input pulled down internally to ground with a 10 k<math>\Omega</math> resistor; when the output enable input function has been activated, each SourceMeter channel will not turn on unless the output enable pin is driven to &gt;2.1 V (nominal current = 2.1 V / 10 k<math>\Omega</math> = 210 <math>\mu</math>A).</p>



Keithley Instruments, Inc.  
28775 Aurora Road  
Cleveland, Ohio 44139  
1-888-KEITHLEY  
www.keithley.com

System SourceMeter® Specifications

Specifications Category	Specifications
Cooling	Forced air. Side intake and rear exhaust. One side must be unobstructed when rack mounted
Warranty	1 year
EMC	Conforms to European Union Directive 2004/108/EEC, EN 61326-1
Safety	Conforms to European Union Directive 73/23/EEC, EN 61010-1, and UL 61010-1
Dimensions	89 mm high × 213 mm wide × 460 mm deep (3½ in × 8⅜ in × 17½ in). Bench Configuration (with handle & feet): 104 mm high × 238 mm wide × 460 mm deep (4⅛ in × 9⅜ in × 17½ in)
Weight	<b>2601A:</b> 4.75 kg (10.4 lbs). <b>2602A:</b> 5.50 kg (12.0 lbs).
Environment	For indoor use only. <b>Altitude:</b> Maximum 2000 meters above sea level <b>Operating:</b> 0°– 50°C, 70% R.H. up to 35°C. Derate 3% R.H./°C, 35°– 50°C <b>Storage:</b> – 25°C to 65°C

Keithley Instruments, Inc.  
 28775 Aurora Road  
 Cleveland, Ohio 44139  
 1-888-KEITHLEY  
 www.keithley.com

**System SourceMeter® Specifications**
**5. MEASUREMENT SPEED SPECIFICATIONS<sup>30,31</sup>**
**Maximum Sweep Operation Rates (operations per second) for 60Hz (50Hz):**

A/D converter speed	Trigger origin	Measure to memory using user scripts	Measure to GPIB using user scripts	Source measure to memory using user scripts	Source measure to GPIB using user scripts	Source measure to memory using sweep API	Source measure to GPIB using sweep API
0.001 NPLC	Internal	20000 (20000)	9800 (9800)	7000 (7000)	6200 (6200)	12000 (12000)	5900 (5900)
0.001 NPLC	Digital I/O	8100 (8100)	7100 (7100)	5500 (5500)	5100 (5100)	11200 (11200)	5700 (5700)
0.01 NPLC	Internal	4900 (4000)	3900 (3400)	3400 (3000)	3200 (2900)	4200 (3700)	4000 (3500)
0.01 NPLC	Digital I/O	3500 (3100)	3400 (3000)	3000 (2700)	2900 (2600)	4150 (3650)	3800 (3400)
0.1 NPLC	Internal	580 (480)	560 (470)	550 (465)	550 (460)	560 (470)	545 (460)
0.1 NPLC	Digital I/O	550 (460)	550 (460)	540 (450)	540 (450)	560 (470)	545 (460)
1.0 NPLC	Internal	59 (49)	59 (49)	59 (49)	59 (49)	59 (49)	59 (49)
1.0 NPLC	Digital I/O	58 (48)	58 (49)	59 (49)	59 (49)	59 (49)	59 (49)

**Maximum Single Measurement Rates (operations per second) for 60Hz (50Hz):**

A/D converter speed	Trigger origin	Measure to GPIB	Source measure to GPIB	Source measure pass/fail to GPIB
0.001 NPLC	Internal	1900 (1800)	1400 (1400)	1400 (1400)
0.01 NPLC	Internal	1450 (1400)	1200 (1100)	1100 (1100)
0.1 NPLC	Internal	450 (390)	425 (370)	425 (375)
1.0 NPLC	Internal	58 (48)	57 (48)	57 (48)

**Maximum measurement range change rate:** >7000/second for >10  $\mu$ A typical. When changing to or from a range  $\geq$ 1A, maximum rate is >2200/second typical.

**Maximum source range change rate:** >400/second >10  $\mu$ A typical. When changing to or from a range  $\geq$ 1A, maximum rate is >190/second typical.

**Maximum source function change rate:** >1000/second, typical.

**Command processing time:** Maximum time required for the output to begin to change following the receipt of the smux.source.levelv or smux.source.leveli command. <1ms typical.

<sup>30</sup> Tests performed with a 2602A on Channel A using the following equipment: Computer hardware (Intel® Pentium® 4 2.4 GHz, 2 GB RAM, National Instruments™ PCI-GPIB). Driver (NI-488.2 Version 2.2 PCI-GPIB). Software (Microsoft® Windows® XP, Microsoft® Visual Studio® 2010, VISA™ version 4.1)

<sup>31</sup> Exclude current measurement ranges less than 1mA.

## 6. TRIGGERING AND SYNCHRONIZATION SPECIFICATIONS

### Triggering:

- Trigger in to trigger out: 0.5 $\mu$ s, typical.
- Trigger in to source change:<sup>32</sup> 10  $\mu$ s, typical.
- Trigger Timer accuracy:  $\pm$ 2 $\mu$ s, typical.
- Source change<sup>32</sup> after LXI Trigger: 280 $\mu$ s, typical.

### Synchronization:

- Single-node synchronized source change:<sup>32</sup> <0.5 $\mu$ s, typical.
- Multi-node synchronized source change:<sup>32</sup> <0.5 $\mu$ s, typical.

## 7. SUPPLEMENTAL INFORMATION

### Front Panel Interface:

Two-line vacuum fluorescent display (VFD) with keypad and rotary knob.

### Display:

- Show error messages and user-defined messages
- Display source and limit settings
- Show current and voltage measurements
- View measurements stored in dedicated reading buffers

### Keypad operations:

- Change host interface settings
- Save and restore instrument setups
- Load and run factory and user-defined test scripts (i.e., sequences) that prompt for input and send results to the display
- Store measurements into dedicated reading buffers

### Programming:

**Embedded Test Script Processor (TSP):** Accessible from any host interface.

- Responds to individual instrument control commands.
- Responds to high-speed test scripts comprised of instrument control commands and Test Script Language (TSL) statements (for example branching, looping, and math).
- Able to execute high-speed test scripts stored in memory without host intervention.

**Minimum user memory available:** 16MB (approximately 250,000 lines of TSL code).

**Test Script Builder:** Integrated development environment for building, running, and managing TSP scripts. Includes an instrument console for communicating with any TSP-enabled instrument in an interactive manner.

Requires:

- VISA (NI-VISA included on CD)
- Microsoft .NET Framework (included on CD)
- Keithley I/O Layer (included on CD)

<sup>32</sup> Fixed source range, with no polarity change.

Keithley Instruments, Inc.  
28775 Aurora Road  
Cleveland, Ohio 44139  
1-888-KEITHLEY  
www.keithley.com

## System SourceMeter® Specifications

- Pentium III 800MHz or faster personal computer
- Microsoft® Windows® 2000, XP, Vista®, or 7

**TSP™ Express (embedded):** Tool that allows users to quickly and easily perform common I-V tests without programming or installing software. To run TSP Express, you need:

- Java™ Platform, Standard Edition 6
- Microsoft® Internet Explorer®, Mozilla® Firefox®, or another Java-compatible web browser

**Software Interface:** TSP Express (embedded), direct GPIB/VISA, read/write with Microsoft® Visual Basic®, Visual C/C++®, Visual C#®, LabVIEW™, CEC TestPoint™ Data Acquisition Software Package, NI LabWindows™/CVI, and so on.

### Reading Buffers:

Non-Volatile memory utilizes dedicated storage area(s) reserved for measurement data. Reading buffers are arrays of measurement elements. Each element can hold the following items:

- Measurement
- Source setting (at the time the measurement was taken)
- Measurement status
- Range information
- Timestamp

Two reading buffers are reserved for each SourceMeter channel. Reading buffers can be filled using the front panel STORE key, and retrieved using the RECALL key or host interface.

**Buffer Size, with timestamp and source setting:** > 60,000 samples.

**Buffer Size, without timestamp and source setting:** > 140,000 samples.

### System Expansion:

The TSP-Link expansion interface allows TSP-enabled instruments to trigger and communicate with each other. See figure below:

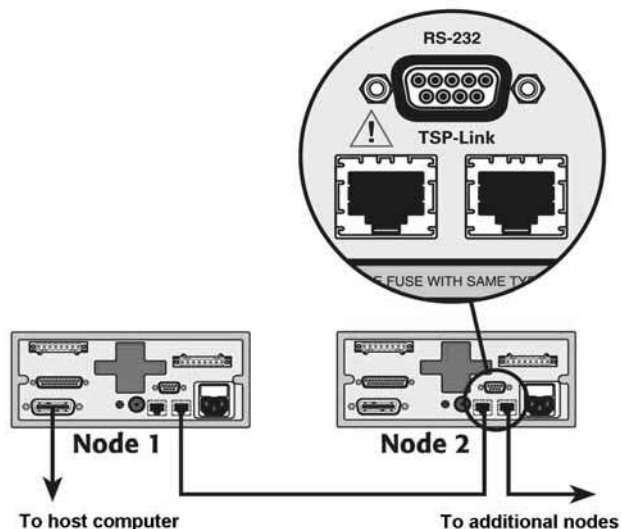

Keithley Instruments, Inc.  
28775 Aurora Road  
Cleveland, Ohio 44139  
1-888-KEITHLEY  
www.keithley.com

---

**System SourceMeter® Specifications**

Each SourceMeter has two TSP-Link connectors to make it easier to connect instruments together in sequence.

- Once SourceMeter instruments are interconnected via TSP-Link, a computer can access all of the resources of each SourceMeter via the host interface of any SourceMeter.
- A maximum of 32 TSP-Link nodes can be interconnected. Each SourceMeter consumes one TSP-Link node.

**TIMER:**

Free-running 47-bit counter with 1MHz clock input. Reset each time instrument powers up. Rolls over every 4 years.

**Timestamp:** TIMER value automatically saved when each measurement is triggered.

**Resolution:** 1 $\mu$ s.

**Timestamp Accuracy:**  $\pm$ 100ppm.