

**Agilent**  
**Agilent 34405A Multimeter**  
**5.5 Digit Dual Display, Benchtop DMM**  
**More Capabilities at a Value Price**

**Data Sheet**



## Features

120000 counts resolution

16 built-in measurement functions including temperature and capacitance

0.025% 1-year DC voltage accuracy

USB 2.0

SCPI compatible

Agilent IO Library Suite and DMM Intuilink connectivity software included

## Affordable and Feature Rich Measurement Tool

With the 34405A digital multimeter, you get all the tools you need at an affordable price without compromising the quality Agilent products are known for. It provides a broad range of features and measurement functions such as DC voltage, DC current, true-RMS AC voltage and AC current, 2-wire resistance, frequency, diode test and continuity which are designed to meet general industrial needs. Furthermore, it can measure temperature ranging from -80 °C to 150 °C. The true value is more evident with its capability to measure capacitance ranging from 1000 pF to 10000 mF. Agilent 34405A also improves efficiency and accuracy with its six built-in math operations: Null, dBm, dB, MinMax, Limit and Hold.

## Quick Connection to the PC with USB 2.0 Interface

For those with a need to control and take preset measurements with a PC, the built-in USB 2.0 interface provides an easy and robust connection between the PC and DMM. The USB interface connects directly to the PC host and works seamlessly with Agilent Connectivity software and can be controlled remotely via industry standard SCPI commands or through DMM Intuilink Connectivity software. IVI-COM and LabVIEW drivers are included to ensure an easy integration with different programming environments.

## Bright Display, Fast Reading Speed and Configuration Storage

When high throughput and productivity are the priority, Agilent 34405A VFD dual display feature allows users to take more than one measurement and display them simultaneously on the front panel. For speed critical applications, Agilent 34405A can take up to 19 readings/sec at 4.5 digits resolution directly to the PC. In addition, the user can configure and store complete instrument setups and recall them at anytime from any of the four built-in storing states.

## Rugged and Reliable

The 34405A is designed and tested according to major Safety and Regulatory Standards. In addition, the shock absorbing bumpers is designed to prevent physical damage from your day-to-day use.

You can watch 34405A in action on your PC by downloading the interactive demo from the 34405A homepage at [www.agilent.com/find/34405a](http://www.agilent.com/find/34405a)

Go to the WEB for more information on Agilent's DMM. Visit [www.agilent.com](http://www.agilent.com)

## DC CHARACTERISTICS<sup>[1]</sup>

FUNCTION	RANGE <sup>[2]</sup>	TEST CURRENT OR BURDEN VOLTAGE	INPUT IMPEDANCE <sup>[3]</sup>	ACCURACY ± (% of reading + % of range)	
				1 Year 23 °C ± 5 °C	Temperature Coefficient 0 °C - 18 °C 28 °C - 55 °C
VOLTAGE	100.000 mV	-	10.0 MΩ±2%	0.025+0.008	0.0015+0.0005
	1.00000 V	-	10.0 MΩ±2%	0.025+0.006	0.0010+0.0005
	10.0000 V	-	10.1 MΩ±2%	0.025+0.005	0.0020+0.0005
	100.000 V	-	10.1 MΩ ±2%	0.025+0.005	0.0020+0.0005
	1000.00 V	-	10.0 MΩ±2%	0.025+0.005	0.0015+0.0005
RESISTANCE	100.000 Ω	1.0 mA	-	0.05+0.008 <sup>[3]</sup>	0.0060+0.0008
	1.00000 kΩ	0.83 mA	-	0.05+0.005 <sup>[3]</sup>	0.0060+0.0005
	10.0000 kΩ	100 μA	-	0.05+0.006 <sup>[3]</sup>	0.0060+0.0005
	100.000 kΩ	10.0 μA	-	0.05+0.007	0.0060+0.0005
	1.00000 MΩ	900 nA	-	0.06+0.007	0.0060+0.0005
	10.0000 MΩ	205 nA	-	0.25+0.005	0.0250+0.0005
	100.000 MΩ	205 nA   10MΩ	-	2.00+0.005	0.3000+0.0005
CURRENT	10.0000 mA	< 0.2 V	-	0.05+0.015	0.0055+0.0005
	100.000 mA	< 0.2 V	-	0.05+0.005	0.0055+0.0005
	1.00000 A	< 0.5 V	-	0.20+0.007	0.0100+0.0005
	10.0000 A	< 0.6 V	-	0.25+0.007	0.0150+0.0005
CONTINUITY	1000 Ω	0.83 mA	-	0.05+0.005	0.0050+0.0005
DIODE TEST <sup>[4]</sup>	1.0000 V	0.83 mA	-	0.05+0.005	0.0050+0.0005

## AC CHARACTERISTICS<sup>[1]</sup>

FUNCTION	RANGE <sup>[5]</sup>	FREQUENCY	ACCURACY ± (% of reading + % of range)	
			1 Year 23 °C ± 5 °C	Temperature Coefficient 0 °C - 18 °C 28 °C - 55 °C
TRUE-RMS AC VOLTAGE <sup>[6]</sup>	100.000 mV	20 Hz - 45 Hz	1.0+0.1	0.02+0.02
		45 Hz - 10 kHz	0.2+0.1	0.02+0.02
		10 kHz - 30 kHz	1.5+0.3	0.05+0.02
		30 kHz - 100 kHz <sup>[7]</sup>	5.0+0.3	0.10+0.02
	1.00000 V to 750.00 V	20 Hz - 45 Hz	1.0+0.1 <sup>[14]</sup>	0.02+0.02
		45 Hz - 10 kHz	0.2+0.1	0.02+0.02
		10 kHz - 30 kHz	1.0+0.1	0.05+0.02
		30 kHz - 100 kHz <sup>[7]</sup>	3.0+0.2 <sup>[15]</sup>	0.10+0.02
TRUE-RMS AC CURRENT <sup>[8]</sup>	10.0000 mA to 10.0000 A	20 Hz - 45 Hz	1.5+0.1	0.02+0.02
		45 Hz - 1 kHz	0.5+0.1	0.02+0.02
		1 kHz - 10 kHz <sup>[9]</sup>	2.0+0.2	0.02+0.02

## AC CHARACTERISTICS<sup>[1]</sup>

FUNCTION	RANGE <sup>[5]</sup>	FREQUENCY	ACCURACY ± (% of reading + % of range)	
			1 Year 23 °C ± 5 °C	Temperature Coefficient 0 °C - 18 °C 28 °C - 55 °C
FREQUENCY <sup>[10]</sup>	100.000 mV to 750.00 V	< 2 Hz	0.18+0.003	0.005
		< 20 Hz	0.04+0.003	0.005
		20 Hz - 100 kHz <sup>[11]</sup>	0.02+0.003	0.005
		100 kHz ~ 300 kHz <sup>[12]</sup>	0.02+0.003	0.005
	10.0000 mA to 10.0000 A	< 2 Hz	0.18+0.003	0.005
		< 20 Hz	0.04+0.003	0.005
		20 Hz ~ 10 kHz <sup>[11]</sup>	0.02+0.003	0.005

## TEMPERATURE and CAPACITANCE CHARACTERISTICS<sup>[1]</sup>

FUNCTION	RANGE	TEST CURRENT, etc.	ACCURACY ± (% of reading + % of range)	
			1 Year 23 °C ± 5 °C	Temperature Coefficient 0 °C - 18 °C 28 °C - 55 °C
TEMPERATURE	-80 °C - 150 °C	5 kΩ thermistor probe	Probe accuracy + 0.2 °C	0.002 °C
	-110.0 °F - 300.0 °F	5 kΩ thermistor probe	Probe accuracy + 0.4 °F	0.0036 °F
CAPACITANCE	1.000 nF	0.75 μA	2.0+0.8	0.02+0.001
	10.00 nF	0.75 μA	1.0+0.5	0.02+0.001
	100.0 nF	8.3 μA	1.0+0.5	0.02+0.001
	1.000 μF - 100.0 μF	83 μA	1.0+0.5	0.02+0.001
	1000 μF	0.83 mA	1.0+0.5	0.02+0.001
	10 000 μF	0.83 mA	2.0+0.5	0.02+0.001

[1] Specifications are for 30 minutes warm-up, 5 1/2 digit resolution and calibration temperature 18 °C - 28 °C.

[2] 20% over range on all ranges except 1000 Vdc.

[3] Specifications are 2-wire ohms using Math Null. If without Math Null, add 0.2 Ω additional error.

[4] Specifications are for the voltage measured at the input terminals only.

[5] 20% over range on all range except 750 Vac

[6] Specifications are for sinewave inputs >5% of range. Maximum crest factor : 3 at full scale.

[7] Additional error to be added as frequency >30 kHz and signal input <10% of range. 30 kHz ~ 100 kHz: 0.003% of full scale per kHz.

[8] For 12 A terminal, 10 A dc or ac rms continuous, >10 A dc or ac rms for 30 seconds ON and 30 seconds OFF.

[9] For 1 A and 10 A ranges, the frequency is verified for less than 5 kHz.

[10] Specifications are for half-hour warm-up, using 0.1 second aperture. The frequency can be measured up 1 MHz as 0.5 V signal to 100 mV/1 V ranges.

[11] For 20 Hz ~ 10 kHz, the sensitivity is AC input current from 10% to 120% of range except where noted.

[12] For 100 kHz ~ 300 kHz, the sensitivity will be 12% ~ 120% of range except 750 V range.

[13] Input Impedance is in paralleled with capacitance <120 pF.

[14] For input <200 V rms

[15] For input <300 V rms

## OPERATING CHARACTERISTICS

Function	Digits	Reading Speed <sup>[1]</sup>	Function Change (sec) <sup>[2]</sup>	Range Change (sec) <sup>[3]</sup>	Auto Range (sec) <sup>[4]</sup>	Reading Speed Over USB/(sec) <sup>[5]</sup>
<b>DCV</b>	5.5	15 /s	0.3	0.3	< 1.2	8
	4.5	70 /s	0.2	0.2	< 1.1	19
<b>DCI</b>	5.5	15 /s	0.4	0.4	<1.0	8
	4.5	70 /s	0.3	0.3	< 0.5	19
<b>ACV</b>	5.5	2.5 /s	1.3	1.7	< 5.7	2
	4.5	2.5 /s	1.2	1.5	< 5.1	2
<b>ACI</b>	5.5	2.5 /s	1.8	2.2	< 4.7	2
	4.5	2.5 /s	1.5	1.9	< 4.0	2
<b>FREQ<sup>[6]</sup></b>	5.5	9 /s	2.8	2.8	< 5.8	1
	4.5	9 /s	2.5	2.5	< 5.0	1

[1] Reading rate of the A/D converter.

[2] Time to change from 2-wire resistance to this specified function and to take at least one reading using SCPI "FUNC" and "READ?" commands.

[3] Time to change from one range to the next higher range and to take at least one reading using SCPI "FUNC" and "READ?" commands.

[4] Time to automatically change one range and to take at least one reading using SCPI "CONF AUTO" and "READ?" commands.

[5] Number of measurements per second that can be read through USB using SCPI "READ?" command.

[6] Reading rate depends on signal frequency >10 Hz.

## DIMENSIONS

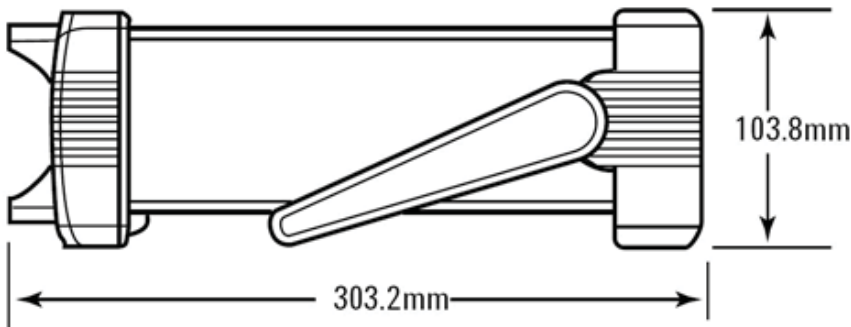
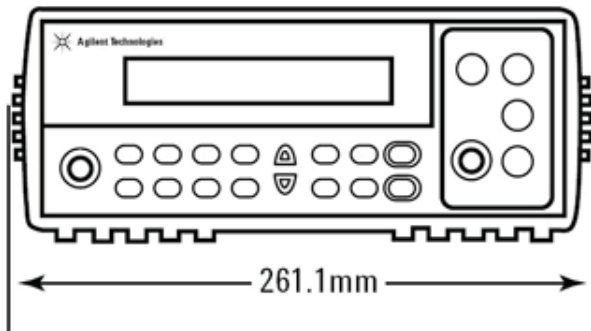

## SUPPLEMENTAL MEASUREMENT CHARACTERISTICS

---

### DC VOLTAGE

Measuring Method:  
Sigma Delta A-to-D converter  
Input Resistance:  
10 M $\Omega$   $\pm$  2% range (typical)  
Input Protection:  
1000 V on all ranges

---

### RESISTANCE

Measuring Method:  
2-wire Ohms  
Open-circuit voltage:  
Limited to < 5V  
Input Protection:  
1000 V on all ranges

---

### DC CURRENT

Shunt Resistance:  
0.1  $\Omega$  to 10  $\Omega$  for 10mA to 1.2 A ranges  
0.01  $\Omega$  for 12 A range  
Input Protection:  
Front Panel 1.25 A, 500 V fuse for I terminal  
Internal 15 A, 600 V fuse for 12 A terminal

---

### CONTINUITY/DIODE TEST

Measuring Method:  
Uses 0.83 mA  $\pm$  0.2% constant current source, < 5 V open circuit voltage  
Response Time:  
70 samples/second with audible tone  
Continuity Threshold:  
10  $\Omega$  fixed  
Input Protection:  
1000 V

---

### TEMPERATURE

Measurement Method:  
2-wire Ohms measurement of 5 k $\Omega$  thermistor sensor (E2308A) with computer conversion  
Auto-ranging measurement, no manual range selection  
Input Protection:  
1000 V

---

### MEASUREMENT NOISE REJECTION

CMRR (Common Mode Rejection) for 1 k $\Omega$  unbalance LO lead

DC	120 dB
AC	70 dB

NMR (Normal Mode Rejection) For 60 Hz (50 Hz)  $\pm$  0.1%

5 1/2 digit	65 dB (55 dB)
4 1/2 digit	0 dB

---

---

### AC VOLTAGE

Measurement Method:  
AC coupled true-RMS - measure the ac component with up to 400 Vdc bias any range  
Crest Factor:  
Maximum 5:1 at full scale  
Input Impedance:  
1 M $\Omega$   $\pm$  2% in parallel with < 100 pF of all ranges  
Input Protection:  
750 Vrms on all ranges

---

### AC CURRENT

Measuring Method:  
DC coupled to the fuse and current shunt, AC coupled true-RMS measurement (measure the AC component only)  
Shunt Resistance:  
0.1  $\Omega$  to 10  $\Omega$  for 10 mA to 1.2 A range  
0.1  $\Omega$  for 12 A range  
Input Protection:  
Externally accessible 1.25 A, 500 V fuse for I terminal  
Internally replaceable 15 A, 600 V fuse for 12 A terminal

---

### FREQUENCY

Measurement Method:  
Reciprocal counting technique. AC coupled input using AC voltage function.  
Signal Level:  
10% of range to full scale input on all ranges  
Auto or manual range selection  
Gate Time:  
0.1 second or 1 period of the input signal, whichever is longer.  
Input Protection:  
750 Vrms on all ranges

---

### MATH FUNCTIONS

Null, dBm, dB, Min/Max/Avg, Hold, Limit Test

---

### TRIGGER and MEMORY

Single trigger, 1 reading memory

---

### REMOTE INTERFACE

USB 2.0 full speed, USBTMC-USB488 device class

---

### PROGRAMMING LANGUAGE

SCPI, IEEE-488.1, IEEE-488.2

---

## GENERAL CHARACTERISTICS

### POWER SUPPLY

100V/120V(127V)/220V(230V)/240V  $\pm$  10%  
AC line frequency 45Hz - 66Hz and (360Hz - 440Hz,  
100/120V operation)

### POWER CONSUMPTION

16VA maximum, <11W average

### OPERATING ENVIRONMENT

Full accuracy at 0 °C to 55 °C  
Full accuracy to 80% RH at 30 °C (non-condensing)  
Altitude up to 3000 meters

### STORAGE COMPLIANCE

- 40 °C to 70 °C

### SAFETY COMPLIANCE

Certified to CSA for IEC/EN/CSA/UL 61010-1 2nd Edition

### MEASUREMENT CATEGORY

CAT II, 300V: CAT I 1000Vdc, 750Vac rms, 2500Vpk  
transient over voltage  
Pollution degree 2

### EMC COMPLIANCE

Certified to IEC/EN 61326:2002, CISPR 11, and  
equivalents for Group 1, Class A

### SHOCK and VIBRATION

Tested to IEC/EN 60086-2

### SHOCK and VIBRATION

Tested to IEC/EN 60086-2

### DIMENSION (HxWxD)

Rack: 88.5mm x 212.6mm x 272.3mm  
Bench: 103.8mm x 261.2mm x 303.2mm

### WEIGHT

3.75 kg, 8.27 lb

### WARM UP TIME

30 minutes

### WARRANTY

One year for 34405A  
Three months for standard shipped accessories

### Standard shipped accessories:

Test lead kit  
Test report  
Power cord  
USB interface cable  
Quick Start Guide  
User's and Service Guide  
Product Reference CD-ROM  
Agilent IO Library Suite CD-ROM

### Options:

Opt. 1CM - Rack mount adapter kit

### Agilent Optional Accessories



34133A Precision Electronics Test Leads



34330A 30A Current Shunt



E2308A Thermistor Probe

# Agilent 34405A Multimeter: Versatile and low cost solution for benchtop testing.

5.5 digit dual display increases productivity and throughput in troubleshooting.

Use the Up-Down keys to select the desired measurement range. Just press Shift -> Auto key to switch measurement range automatically.

Superior value with a broad range of functions, which includes the temperature and capacitance measurements.



Connect the supplied test leads to the Input Terminals to start your measurements.

Selecting the secondary display measurements.

Math functions and utility menu that allow users to take reference measurements (ie. Min/Max value and etc.) and store the measurement setups from the front panel.





### Agilent Email Updates

[www.agilent.com/find/emailupdates](http://www.agilent.com/find/emailupdates)  
Get the latest information on the products and applications you select.



### Agilent Direct

[www.agilent.com/find/agilentdirect](http://www.agilent.com/find/agilentdirect)  
Quickly choose and use your test equipment solutions with confidence.



### www.agilent.com/find/open

Agilent Open simplifies the process of connecting and programming test systems to help engineers design, validate and manufacture electronic products. Agilent offers open connectivity for a broad range of system-ready instruments, open industry software, PC-standard I/O and global support, which are combined to more easily integrate test system development.

### Remove all doubt

Our repair and calibration services will get your equipment back to you, performing like new, when promised. You will get full value out of your Agilent equipment throughout its lifetime. Your equipment will be serviced by Agilent-trained technicians using the latest factory calibration procedures, automated repair diagnostics and genuine parts. You will always have the utmost confidence in your measurements.

Agilent offers a wide range of additional expert test and measurement services for your equipment, including initial start-up assistance onsite education and training, as well as design, system integration, and project management.

For more information on repair and calibration services, go to

[www.agilent.com/find/removealldoubt](http://www.agilent.com/find/removealldoubt)

Product specifications and descriptions in this document subject to change without notice.

[www.agilent.com](http://www.agilent.com)

[www.agilent.com/find/34405A](http://www.agilent.com/find/34405A)

For more information on Agilent Technologies' products, applications or services, please contact your local Agilent office. The complete list is available at:

[www.agilent.com/find/contactus](http://www.agilent.com/find/contactus)

#### Phone or Fax Americas

Canada	(877) 894-4414
Latin America	305 269 7500
United States	(800) 829-4444

#### Asia Pacific

Australia	1 800 629 485
China	800 810 0189
Hong Kong	800 938 693
India	1 800 112 929
Japan	0120 (421) 345
Korea	080 769 0800
Malaysia	1 800 888 848
Singapore	1 800 375 8100
Taiwan	0800 047 866
Thailand	1 800 226 008

#### Europe & Middle East

Austria	01 36027 71571
Belgium	32 (0) 2 404 93 40
Denmark	45 70 13 15 15
Finland	358 (0) 10 855 2100
France	0825 010 700* *0.125€/minute
Germany	07031 464 6333
Ireland	1890 924 204
Israel	972-3-9288-504/544
Italy	39 02 92 60 8484
Netherlands	31 (0) 20 547 2111
Spain	34 (91) 631 3300
Sweden	0200-88 22 55
Switzerland	0800 80 53 53
United Kingdom	44 (0) 118 9276201

Other European Countries:

[www.agilent.com/find/contactus](http://www.agilent.com/find/contactus)

Revised: October 6, 2008

© Agilent Technologies, Inc. 2009  
Printed in USA, August 11, 2009  
5989-4906EN



**Agilent Technologies**