

# Agilent 8510C Network Analyzer Family

45 MHz to 110 GHz

## Configuration Guide

The Agilent Technologies 8510C is a modular family of compatible products. For flexibility in specifying a solution that meets your exact needs, a system is typically ordered as separate line items. For those who wish ordering convenience, complete bundled systems are available. Whether ordering individual components or a bundled system, all 8510C network analyzers include one-year, on-site service. For systems built from individual components, installation may be ordered separately. A PC running BASIC Rev 6.3 or higher under Windows® (3.1/95/NT) is recommended for installation and service.

### Complete systems

#### Agilent 8510XF family 110 GHz single sweep systems (45 MHz to 110 GHz)

The 8510XF family has two models which are complete single-connection, single-sweep vector network analyzer systems that offer S-parameter measurements over an ultra-broadband frequency in a 1.0 mm coaxial connector. The broadest frequency model covers 45 MHz to 110 GHz. A lower frequency model is available covering 45 MHz to 85 GHz. Both systems are designed to facilitate easy connection to wafer probe hardware while still preserving excellent RF measurement performance. In addition, the system can be used to make coaxial measurements (to interface to a coaxial fixture or a coaxial DUT) using the same millimeter head configuration.

#### Agilent E7340A single-connection single-sweep network analyzer system (2 to 85 GHz)

The E7340A is a complete system configured with an 8510C, a 20 GHz and 50 GHz synthesizer, two 85 GHz S-parameter test heads, and a millimeter test set controller. The instruments are integrated in the system rack, the system is fully tested, and a complete system verification is performed prior to shipment from Agilent. Installation is included at no additional charge. The E7340A system does not include calibration kits or test port cable sets.

System components include:

- 8510C network analyzer
- E7342A millimeter subsystem
- 83621B synthesizer
- 83651B synthesizer
- System rack

*Calibration kits and test port cables are not included and must be ordered separately.*

#### Test set options

- **E7340A-STD** Standard configuration
- **E7340A-005** Add (45 MHz to 2 GHz) low frequency extension
- **E7340A-006** Add RF pass thru (provides coupled output of 50 GHz source for additional test set(s). Additional test set(s) must have Option 001 installed)
- **E7340A-056** Low frequency extension and RF pass through

#### Features

- **8510C-010** Add time domain

#### Voltage options

- **E7340A-115** 110/120 V line voltage operation
- **E7340A-230** 220/240 V line voltage operation

Extended service options are available.



Agilent Technologies

### **Agilent E7350A single-connection single-sweep network analyzer system (2 to 110 GHz)**

The E7350A is a complete system configured with an 8510C, a 20 GHz and 50 GHz synthesizer, two 110 GHz S-parameter test heads, and a millimeter test set controller. The instruments are integrated in the system rack, the system is fully tested, and a complete system verification is performed prior to shipment from Agilent. Installation is included at no additional charge. The E7350A system does not include calibration kits or test port cable sets.

System components include:

- 8510C network analyzer
- E7352A millimeter subsystem
- 83621B synthesizer
- 83651B synthesizer
- System rack

*Calibration kits and test port cables are not included and must be ordered separately.*

#### **Test set options**

- **E7340A-STD** Standard configuration
- **E7340A-005** Add (45 MHz to 2 GHz) low frequency extension
- **E7340A-006** Add RF pass thru (provides coupled output of 50 GHz source for additional test set(s). Additional test set(s) must have Option 001 installed)
- **E7340A-056** Low frequency extension and RF pass through

#### **Features**

- **8510C-010** Add time domain

#### **Voltage options**

- **E7340A-115** 110/120 V line voltage operation
- **E7340A-230** 220/240 V line voltage operation

Extended service options are available.

### **Agilent 85107B network analyzer system**

(45 MHz to 50 GHz)

The 85107B is a complete system configured with a 50 GHz synthesizer, 50 GHz S-parameter test set, and 2.4 mm measurement accessories. The instruments are integrated in the system rack, the system is fully tested, and a complete system verification is performed prior to shipment from the factory. Installation is included at no additional charge.

System components include:

- 8510C network analyzer
- 8517B test set with Option 002 (deleted step attenuators and bias tees)
- 83651B synthesizer
- 85056A calibration kit
- 85133F cable set
- 85043C rack

#### **Test set options**

- **85107B-STD** Standard configuration
- **85107B-005** Add attenuators and bias network (not compatible with 85107B-STD)
- **85107B-007** High power and high dynamic range configuration (requires 85107B-005)

#### **Source options**

- **85107B-51B** Standard 50 GHz synthesized sweeper, no front panel
- **85107B-50B** 50 GHz synthesized source with front panel
- **85107B-50L** 50 GHz CW synthesized source with front panel

#### **Features**

- **8510C-010** Add time domain

#### **Voltage options**

- **85107B-115** 110/120 V line voltage operation
- **85107B-230** 220/240 V line voltage operation

#### **Accessories**

- **85107B-002** 2.4mm calibration kit and cables
- **85107B-001** 3.5mm calibration kit and cables
- **85107B-E33** Do not include 2.4mm kit and cables (not compatible with 85107B-002)

Extended service options are available.

### Agilent 8510SX network analyzer system

(45 MHz to 26.5 GHz)

The 8510SX is a complete system configured with a 26.5 GHz synthesizer, 26.5 GHz S-parameter test set, and a complete set of 3.5 mm measurement accessories. The instruments are integrated in the system rack, the system is fully tested, and a complete system verification is performed prior to shipment from the factory. Installation is included at no additional charge.

System components include:

- 8510C network analyzer
- 8515A test set
- 83631B synthesizer
- 85043C rack
- 85052C calibration kit
- 11752D gauge kit
- 85131F cable set

#### Features

- **8510C-010** Add time domain

#### Voltage options

- **8510SX-115** 110/120 V line voltage operation
- **8510SX-230** 220/240 V line voltage operation

#### Accessories

- **8510SX-001** 7 mm accessories (85052C and 85132F)

Extended service options are available.

### Agilent 8510E network analyzer system

(45 MHz to 20 GHz)

The 8510E is a complete unranked system configured with a 20 GHz synthesizer, 20 GHz S-parameter test set, and 3.5 mm connector accessories. Installation is not included.

System components include:

- 8510C network analyzer
- 8514B test set with Option 002  
(deleted step attenuators and bias tees)
- 83621B synthesizer
- 85052D calibration kit
- 85131D cable set

### Test set attenuation options

- **8510E-STD** Standard configuration
- **8510E-002** Add attenuator and bias network

#### Features

- **8510C-010** Add time domain

#### Calibration kit options (select one)

- **8510E-004** 3.5mm economy calibration kit
- **8510E-005** 3.5mm precision calibration kit

Extended service options are available.

### Agilent 85106D millimeter-wave network analyzer subsystem (33 GHz to 110 GHz)

When combined with the appropriate 85104A series test set modules (see page 6) and 11644A series calibration kits, the 85106D provides a complete system for measurements in the millimeter-wave frequency range. The instruments are integrated in a 1600 mm system rack. It is fully tested and a complete system verification is performed prior to shipment from the factory. Installation is included at no additional charge.

The 85106D system consists of:

- 8510C network analyzer
- 85105A test set controller
- 83621B synthesizer (2 total)
- 1600 mm rack

*Must also order appropriate 85104A series test set modules and 11644A series calibration kit for complete system.*

#### Frequency range (select one)

- **85106D-STD** 33 - 110 GHz
- **85106D-001** 45 MHz - 110 GHz, adds 8517B and needed accessories
- **85106D-007** 45 MHz - 110 GHz, high power/high dynamic range

#### Features

- **8510C-010** Add time domain

#### Voltage options

- **85106D-115** 110/120 V line voltage operation
- **85106D-230** 220/240 V line voltage operation

Extended service options are available.

### **Agilent 85108A pulsed-RF network analyzer system**

(2 GHz to 20 GHz)

Based on an 8510C with Option 008, this system provides the capability to measure the amplitude and phase response of a device or component being driven with a pulsed-RF input signal. The instruments are integrated in a 1600 mm system rack. It is fully tested and a complete system verification is performed prior to shipment from the factory. Installation is included at no additional charge.

System components include:

- 8510C network analyzer with Option 008 (pulsed-RF measurement capability)
- 85110A test set
- 1600 mm rack
- 83622B synthesizer with Options 001/004/008
- 83623L synthesizer with Options 004/008
- Calibration kits and test port cables in the appropriate connector interface are not included and must be ordered separately.*

#### **Frequency range (select one)**

- **85108A-STD** 2 - 20 GHz
- **85108A-E63** 500 MHz - 20 GHz
- **85108A-F61** 2 - 50 GHz with front panel connectors
- **85108A-F62** 45 MHz - 50 GHz

#### **Features**

- **8510C-010** Add time domain

#### **Voltage options**

- **85108A-115** 110/120 V line voltage operation
- **85108A-230** 220/240 V line voltage operation

Extended service options are available.

### **Agilent 85108L pulsed-RF network analyzer system**

(45 MHz to 2 GHz)

Based on an 8510C with Option 008, this system provides the capability to measure the amplitude and phase response of a device or component being driven with a pulsed-RF input signal. The instruments are integrated in a 1600 mm system rack, the system is fully tested, and a complete system verification is performed prior to shipment from the factory. Installation is included at no additional charge.

System components include:

- 8510C network analyzer with Option 008 (pulsed-RF measurement capability)
- 85110L test set
- 1600 mm rack
- 83620B synthesizer with Options 001/004/008/H80
- 83620B synthesizer with Options 004/008/H80
- Calibration kits and test port cables in the appropriate connector interface are not included and must be ordered separately.*

#### **Features**

- **8510C-010** Add time domain

#### **Voltage options**

- **85108L-115** 110/120 V line voltage operation
- **85108L-230** 220/240 V line voltage operation

Extended service options are available.

### **Agilent 85122A high frequency device modeling system**

(45 MHz to 20 GHz)

When combined with the 85190 series high frequency IC-CAP software, along with Cascade probes or ICM fixtures, the 85122A can be used to model BJT, FET, MOS, and diode devices. All instruments are integrated in a 1600 mm system rack prior to shipment from the factory. Installation is included at no additional charge.

System components include:

- 8510C network analyzer
- 8514B test set
- 83621B synthesizer
- 11612A Option K10/K20 force/sense bias networks
- 4156C DC source/monitor
- 85131F cable set
- 1600 mm rack
- Probes, fixtures, calibration kits, 85190 series software, and workstation must be ordered separately.*

- **Option 230** provides system cabinet set up for 220/240 V operation

Custom configurations available to meet other frequency coverage and power requirements.

## System components

For flexibility in specifying a solution that meets your exact needs, a system can be ordered as separate line items. A complete system includes the Agilent 8510C network analyzer, a test set, compatible source, and measurement accessories.

All major system components (network analyzer, test sets, and sources) include one-year on-site service.

### 8510C ATO options

- **8510C-008** Pulsed-RF capability requiring 85110A or 85110L S-parameter test set
- **8510C-010** Add time domain

### Rack flange kits

- **8510C-908** Rack flange kit, front handles detached
- **8510C-913** Rack flange kit, front handles attached

### Additional documentation

- **8510C-910** Extra operating and service manual set
- **8510C-916** Extra operating and programming manual set

Extended service options are available.

## Test sets (Choose one)

- **8514B S-parameter test set** (45 MHz to 20 GHz)  
With rugged 3.5 mm connector test ports
- **8515A S-parameter test set** (45 MHz to 26.5 GHz)  
With rugged 3.5 mm connector test ports
- **8517B S-parameter test set** (45 MHz to 50 GHz)  
With rugged 2.4 mm connector test ports
- **85110A pulsed-RF S-parameter test set** (2 to 20 GHz)  
For use with 8510C Option 008. Includes rugged 3.5 mm connector test ports and four built-in step attenuators to independently set power level to all four downconverter channels. Requires 8360 series synthesized sources for complete operation (83622B and 83623L).
- **85110L pulsed-RF S-parameter test set** (45 MHz to 2 GHz)  
For use with 8510C Option 008. Includes rugged 7 mm connector test ports and four built-in step attenuators to independently set power level to all four downconverter channels. Requires two 8360 series synthesized sources for complete operation (83620B-H80, two each).
- **8511A frequency converter** (45 MHz to 26.5 GHz)  
3.5 mm connector ports
- **8511B frequency converter** (45 MHz to 50 GHz)  
2.4 mm connector ports

**Note:** Agilent 8511A/B require external, customer-furnished couplers, or signal separating devices to provide complete test set capability. A source with front panel RF power output may be more suitable for 8511-based applications.

## Test set options

Option	Description	8514B	8515A	8517B	85110A	85110L	8511A/B
STD	No IF switching	X	X				
001	Add IF switching for multiple test set operation	X	X	X	X	X	X
002	Delete step attenuators and bias tees	X	X	X			
003	High forward dynamic range configuration (degrades reverse transmission dynamic range)	X					
003	Add attenuators and bias tees		X	X			
999	Standard input power			X			
004	High power configuration (moves port 2 attenuator in front of b2 sampler)			X			
004	Add attenuators and bias tees	X					
027	High source power			X			
908	Add rack flange kit	X		X			
913	Add rack flange and handles kit	X		X	X		X
910	Extra operating and service manual			X	X		X

## Millimeter-wave test sets and controllers

### Banded waveguide millimeter-wave subsystem

(Components of 85106D)

- **85105A millimeter-wave test set controller**

Requires addition of two 85104A series modules for complete waveguide S-parameter test set operation. Includes IF switching capability and 26.5 GHz RF switching for multiple test set operation.

**85105A-STD** Standard configuration

**85105A-050** 50 GHz RF source switch (Required when used with 83651B 50 GHz source.)

Must also order two test set modules for complete waveguide S-parameter test set operation for each waveguide band:

- **Q85104A test set module** (33 GHz to 50 GHz)
- **U85104A test set module** (40 GHz to 60 GHz)
- **V85104A test set module** (50 GHz to 75 GHz)
- **W85104A test set module** (75 GHz to 110 GHz)

Extended service options are available.

## Sources

*Choose an 8360 series synthesized sweeper*

- **83651B synthesized sweeper** (45 MHz to 50 GHz)
- **83631B synthesized sweeper** (45 MHz to 26.5 GHz)
- **83621B synthesized sweeper** (45 MHz to 20 GHz)
- **83620B-H80 synthesized sweeper** (45 MHz to 2 GHz) for 85110L only
- **83622B synthesized sweeper** (2 GHz to 20 GHz) for 85110A
- **83623L synthesized sweeper** (45 MHz to 20 GHz) for 85110A

## Common options for RF sources

Option	Description
908	Add rack flange kit
910	Extra operating and service manual
913	Add rack flange and handles kit

Extended service options are available.

Note: Although general purpose (GP) 8360 series synthesized sweepers (836x0B) can be used in place of the 8510-dedicated 8360 series synthesized sweepers (836x1B, as listed above), the following options are typically recommended: Option 004 (rear panel connectors) and Option 008 (1-Hz frequency resolution). These options come as standard in the 8510-dedicated 8360 series synthesized sweepers.

## Measurement accessories

There are measurement accessories for seven device connector types: 7 mm, 3.5 mm, 2.92 mm, 2.4 mm, 1.85 mm, 1.0 mm, and Type-N. Calibration kits include standards that are required for vector error correction. Verification kits include standards used to verify system performance specifications. Test port return cables extend the ports of the test set and connect to the device under test. Agilent 85130X adapter sets convert test set ports to the same connector type (acting as a test port saver) or to a different connector type.

## Calibration kits

Error correction requires that the systematic errors in the measurement system be characterized by measuring known devices (standards) over the frequency range of interest with the process of calibration. All calibration kits contain standards used for this purpose. The standards in the 3.5 mm,

2.4 mm, and Type-N calibration kits use the precision slotless connector (PSC-3.5, PSC-2.4, and PSC-N). Unless otherwise noted all coaxial calibration kits include connector gauges and a torque wrench. Option 002 provides calibration kit data on magnetic tape for use with the 8510A/B (not available with 85059A).

Mechanical calibration Kit	Connector type	Frequency range (GHz)	Description
85050B	7 mm	0.045 to 18	Contains open and short circuits, fixed and sliding terminations.
85050C	7 mm	0.045 to 18	Precision kit. Contains standards for TRL calibration, including precision airline. Also contains open and short circuits and fixed termination.
85050D	7 mm	0.045 to 18	Economy kit. Contains open and short circuits and precision fixed termination. Gauges not included.
85052B	3.5 mm	0.045 to 26.5	Contains open and short circuits, fixed and sliding terminations, and in-series adapters.
85052C	3.5 mm	0.045 to 26.5	Precision kit. Contains standards for TRL calibration, including precision airlines. Also contains open and short circuits, fixed terminations, and in-series adapters. Gauges not included.
85052D	3.5 mm	0.045 to 26.5	Economy kit. Contains open and short circuits, precision fixed termination, and in-series adapters. Gauges not included.
85054B	Type-N	0.045 to 18	Contains open and short circuits, fixed and sliding terminations, in-series adapters, and 7 mm-to-Type-N adapters.
85054D	Type-N	0.045 to 18	Economy kit. Contains open and short circuits, fixed terminations, in-series adapters and 7 mm-to-Type-N adapters. Gauges not included.
85056A	2.4 mm	0.045 to 50	Contains open and short circuits, fixed and sliding terminations, and in-series adapters.
85056D	2.4 mm	0.045 to 50	Economy kit. Contains open and short circuits, fixed terminations, and in-series adapters. Gauges not included.
85056K	2.92/2.4 mm	0.045 to 50	Contains 2.4 mm open and short circuits, fixed loads, and 2.92 mm adapters.
85059A	1.0 mm	0.045 to 110	Broadband coaxial precision calibration kit consists of 1.0 mm shorts, opens, fixed loads, and in-series adapters. It also includes offset-shorts covering 50 to 110 GHz. Gauges not included.
11904S	2.92 mm	0.045 to 40	Must be used with 85056A/D 2.4 mm calibration kit. Includes four 2.92-mm-to-2.4-mm adapters. Gauges not included.
X11644A	WR-90	8.2 to 12.4	
P11644A	WR-62	12.4 to 18	
K11644A	WR-42	18.0 to 26.5	
R11644A	WR-28	26.5 to 40	Contains standards for TRL calibration. Includes precision waveguide section, short circuit, and fixed or sliding terminations. Gauges not included.
Q11644A	WR-22	33 to 50	
U11644A	WR-19	40 to 60	
V11644A	WR-15	50 to 75	
W11644A	WR-10	75 to 110	



## Verification kits

Verification kits are used to verify the performance specifications of an Agilent 8510 system. All kits include a precision  $Z_0$  airline, mismatched airline, and fixed attenuators. Measured data and uncertainties traceable to the U.S. National Institute of Standards and Technology (NIST) are included with each kit. Compliance with MIL-STD 45662A is available for an extra charge (Option 1BP). Option 002 provides verification kit data on magnetic tape for use with the 8510A/B.

### Choose a verification kit for each connector type required.

Verification kit	Connector type	Frequency range (GHz)
85051B	7 mm	0.045 to 18
85053B	3.5 mm	0.045 to 26.5
85055A	Type-N	0.045 to 18
85057B	2.4 mm	0.045 to 50
R11645A	WR-28	26.5 to 40
Q11645A	WR-22	33 to 50
U11645A	WR-19	40 to 60
V11645A	WR-15	50 to 75
W11645A	WR-10	75 to 110

## Test port cables and adapters

Test port cables and adapter sets are available for various connector types. Special test port adapter sets convert the rugged ports of the network analyzer test set to the desired connector interface. Each kit contains two adapters, one male and one female. Both the cables and the test port adapters have one special female connector which is designed to connect directly to the 3.5 mm test port (2.4 mm for 8517B). This side of the cable or adapter can only be connected to the test set port and cannot be mated to a standard 3.5 mm (or 2.4 mm) male connector. Choose one of the configurations shown.

**Configuration A.** This cable arrangement is for applications where the device under test is connected directly to the test set port. This setup offers the best mechanical rigidity for device connection. To adapt the test set port (port 1) to the device under test, choose the appropriate special adapter set. In addition to converting the test port to the desired interface, these adapters also function as “test port savers” which protect the test set from damage and wear due to heavy use.

### For Agilent 8514B/8515A/85110A test sets (3.5 mm rugged test port connectors)

	Cables/adapters	Connector type (on device side of cable/adapter)
For 3.5 mm devices	85131C semi-rigid cable or 85131E flexible cable 85130D adapter set	3.5 mm (f) 3.5 mm (f) 3.5 mm (m and f)
For 7 mm devices	85132C semi-rigid cable or 85132E flexible cable 85130B adapter set	7 mm 7 mm 7 mm
For Type-N devices	Use 7 mm cables and the 7-mm-to-Type-N adapters included in the 85054B/D Type-N calibration kit	

### For Agilent 8517B test sets (2.4 mm rugged test port connectors)

	Cables/adapters	Connector type (on device side of cable/adapter)
For 2.4 mm devices	85133C semi-rigid cable or 85133E flexible cable 85130G adapter set	2.4 mm (f) 2.4 mm (f) 2.4 mm (m and f)
For 3.5 mm devices	85134C semi-rigid cable or 85134E flexible cable 85130F adapter set	3.5 mm (f) 3.5 mm (f) 3.5 mm (m and f)
For 7 mm devices	85135C semi-rigid cable or 85135E flexible cable 85130E adapter set	7 mm 7 mm 7 mm

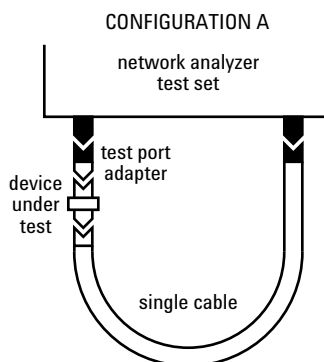

**Configuration B.** This cable arrangement is for applications where the device under test is connected between cable ends. This setup offers more flexibility when connecting to the device under test.

**For Agilent 8514B/8515A/85110A test sets  
(3.5 mm rugged test port connectors)**

	Cables/adapters	Connector type (on device side of cable/adaptor)
For 3.5 mm devices	85131D semi-rigid cable set or 85131F flexible cable set	3.5 mm (m and f) 3.5 mm (m and f)
For 7 mm devices	85132D semi-rigid cable set or 85132F flexible cable set	7 mm 7 mm
For Type-N devices	Use 7 mm cables and the 7-mm-to-Type-N adapters included in the 85054B/D Type-N calibration kit	

**For Agilent 85110L test sets  
(7 mm rugged test port connectors)**

	Cables/adapters	Connector type (on device side of cable/adaptor)
For 7 mm devices	11857D cable pair	7 mm

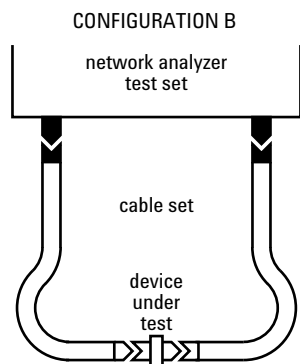

**For Agilent 8517B test sets  
(2.4 mm rugged test port connectors)**

	Cables/adapters	Connector type (on device side of cable/adaptor)
For 2.4 mm devices	85133D semi-rigid cable set or 85133F flexible cable set	2.4 mm (m and f) 2.4 mm (m and f)
For 3.5 mm devices	85134D semi-rigid cable set or 85134F flexible cable set	3.5 mm (m and f) 3.5 mm (m and f)
For 7 mm devices	85135D semi-rigid cable set or 85135F flexible cable set	7 mm 7 mm

**For Agilent 8510XF systems (1.0 mm test port connectors)**

	Cables/adapters	Connector type
For 1.0 mm devices	11500I (8.8 cm) test port cable 11500J (16 cm) test port cable 11500K (20 cm) test port cable 11500L (24 cm) test port cable	1.0 mm (f and f) 1.0 mm (m and f) 1.0 mm (m and f) 1.0 mm (m and f)
For V-band waveguide devices	V281C adapter V281D adapter	1.0 mm (f) to V-band waveguide devices 1.0 mm (m) to V-band waveguide devices
For W-band waveguide devices	W281C adapter W281D adapter	1.0 mm (f) to W-band waveguide devices 1.0 mm (m) to W-band waveguide devices

## Test configuration accessories

### Power meter and power sensors

- **E4418A power meter and 8480 series power sensors**  
Required for use with test port power flatness correction feature.

### Bias supply

- **6626A precision DC power supply**  
For connection to 851XA test set bias input, also order 14852A.
- **14852A bias interconnect cable**

### Bias networks

For supplying DC bias externally from the test set. Standard S-parameter test sets include bias networks.

#### 11590B bias network

Frequency options

- **11590B-101** 100 MHz - 12.4 GHz with Type-N connectors (0.5A maximum current)
- **11590B-001** 100 MHz - 18 GHz with 7mm connectors (0.5A maximum current)

#### 11612A bias network with 3.5 mm connectors

- **11612A-001** 2 amps maximum current (400 MHz - 26.5 GHz)
- **11612B-002** 0.5 amps maximum current (45 MHz - 26.5 GHz)

**11612B bias network** (45 MHz to 50 GHz) with 2.4 mm connectors (0.5A maximum current)

### Amplifier

**8349B microwave amplifier** (2 - 20 GHz) May be used to increase input power level to S-parameter test sets and increase system dynamic range.

- **8349B-001** Recommended (rear panel in/out installed) for use in racked configurations
- **8349B-UN1** Standard configuration (front panel in/out)

### System rack

- **85043C system rack kit**  
132 cm (52 in.) high x 60 cm (23.6 in.) wide x 90.5 cm (35.6 in.) deep. Supplied with anti-static mat (part number 85043-80013), support rails, rack mounting kits (Option 913), and power distribution. Includes two 10833A GPIB cables for connecting system peripherals to 8510C.  
**85043C-115** 110/120 V line operation  
**85043C-230** 220/240 V line operation

## System software

Compatible with a PC, running BASIC Rev 2.1 (85161B) or Windows (95/98/2000 ME/NT). Comes in 3.5-inch disk media.

- **85161B measurement automation software**
- **85070D materials measurement software/probe kit** (PC version)
- **85071D materials measurement software** (PC version)

## Peripherals

Hardcopy results may be output directly to a printer or plotter over the system bus (GPIB compatible) or serial output ports (RS-232-C) without the need of an external computer. Measurement data, calibration sets and kits, and instrument states may be stored on disk using either the built-in disk drive or an external disk drive. GPIB cables must be ordered for each peripheral. Two serial interface (RS-232-C) cables are included with 8510C.

## Graphics printers

HP C2678A DeskJet 1120C Color Printer  
HP C2679A DeskJet 1120Cse Color Printer  
HP C2680A DeskJet 1120Cxi Color Printer  
HP C5876A DeskJet 890Cxi Color Printer  
HP C5877A DeskJet 890Cse Color Printer  
HP C3941A LaserJet 5L Printer  
HP C3150A LaserJet 5P Printer

## GPIB cables

- 10833A 1-Meter GPIB cable
- 10833B 2-Meter GPIB cable
- 10833D 0.5-Meter GPIB cable

## System upgrades

### Upgrades available for existing Agilent 8510 systems to 8510XF single-sweep systems

Upgrades from ...	85107B 85109C	85106C 85106C w/ Opt.002 85106D	85106C w/ Opt.001 & 002 85106D w/ Opt.001 85109C w/ Opt.002
... to 85 GHz	E7345A	E7346A	E7347A
... to 110 GHz	E7355A	E7356A	E7357A

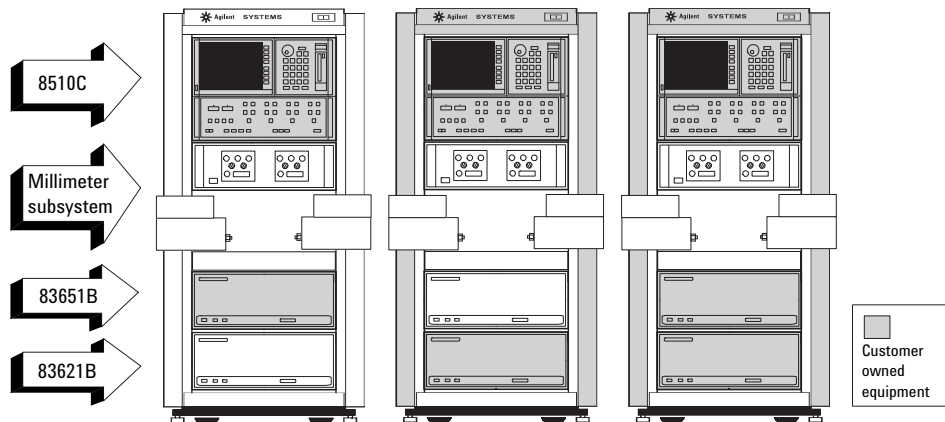

#### Upgrades for 85107B and 85109C

Upgrade consists of two test heads, a millimeter test set controller, an 83621B for LO source, and rack. It does not include calibration kits or test port cables.

- **E7345A** upgrade to an 8510XF 85 GHz system
  - **E7355A** upgrade to an 8510XF 110 GHz system
- The following options are available for both upgrades:
- **E73x5A-STD** Standard configuration
  - **E73x5A-005** Add 45 MHz to 2 GHz low frequency extension
  - **E73x5A-006** Add RF pass thru (provides coupled output of 50 GHz source for additional test sets. Additional test set(s) must have option 001 installed.)
  - **E73x5A-056** Add both low frequency extension and RF pass thru

#### Upgrades for 85106C, 85106C with Option 002 (replaced 8350B/83540A with 83621A/B) 85106D

Upgrade consists of two test heads, a millimeter test set controller, and an 83651B for RF source. It does not include calibration kits, test port cables, or rack.

- **E7346A** upgrade to an 8510XF 85 GHz system
- **E7356A** upgrade to an 8510XF 110 GHz system

The following options are available for both upgrades:

- **E73x6A-STD** Standard configuration
- **E73x6A-005** Add 45 MHz to 2 GHz low frequency extension
- **E73x6A-006** Add RF pass thru (provides coupled output of 50 GHz source for additional test sets. Additional test set(s) must have option 001 installed.)
- **E73x6A-056** Add both low frequency extension and RF pass thru

**Upgrades for 85106C-001 and 85106C-002** (added 8517B, replaced 83621A/B with 83651A/B, and replaced 8350B/83540A with 83621A/B)

- **85106D-001** (added 8517B and replaced 83621B with 83651B)
- **85109C-002** (replaced 8350B/83540A with 83621A/B)  
Upgrade consists of two test heads and a millimeter test set. It does not include calibration kits, test port cables or rack.
- **E7347A** upgrade to an 8510XF 85 GHz system
- **E7357A** upgrade to an 8510XF 110 GHz system

The following options are available for both upgrades:

- **E73x7A-STD** Standard configuration
- **E73x7A-005** Add 45 MHz to 2 GHz low frequency extension
- **E73x7A-006** Add RF pass thru (provides coupled output of 50 GHz source for additional test sets. Additional test set(s) must have option 001 installed.)
- **E73x7A-056** Add both low frequency extension and RF pass thru

## Instrument and firmware upgrades

### Upgrades for 8510A

**8510C Upgrade** (includes on-site installation by Agilent Customer Engineer)

- **85103E** 8510A to 8510C upgrade (replaces the top unit on the 8510A)
- **85103E-001** adds rack modification kit (for systems mounted in an 85043A system rack)
- **85103E-002** adds 8360 series source compatibility kit for 8517A/B test sets
- **85103E-003** adds 8360 series source compatibility kit for the 8514/15 and 85110A test sets
- **85103E-004** adds 8360 source compatibility kit for the 85110L test set

#### Time domain upgrade

- **85012A** time domain (Option 010) upgrade for 8510A (customer installed)

### Upgrades for 8510B

**8510C Upgrade** (includes on-site installation by Agilent Customer Engineer)

- **85103F** 8510B to 8510C upgrade (replaces the top unit on the 8510B)
- **85103F-001** adds rack modification kit (for systems mounted in a 85043A system rack)
- **85103F-002** adds 8360 series source compatibility kit for 8517A/B test sets
- **85103F-003** adds 8360 series source compatibility kit for the 8514/15 and 85110A test sets
- **85103F-004** adds 8360 source compatibility kit for the 85110L test set

### Upgrades for 8510C

**Wideband IF detector upgrade** (reference to 85108A for additional hardware requirements)

- **85111B** pulsed-RF measurement capability upgrade for the 8510C (upgrade adds circuitry to the 8510C and includes on-site installation by Agilent Customer Engineer)

#### Time domain upgrade

- **85012C** time domain (Option 010) upgrade for 8510C (customer installed)

#### Firmware upgrades for 8510C

- **11575J** revision 7.xx upgrade (customer installed)  
For any revision of 8510C firmware currently installed.
- **11575J-002** adds 8360 series source compatibility kit for 8517A/B test sets
- **11575J-003** adds 8360 series source compatibility kit for the 8514/15 and 85110A test sets
- **11575J-004** adds 8360 source compatibility kit for the 85110L test set

## Test set upgrades

For any Agilent 8510 test set

- **08511-60008** add IF switching (Option 001) for multiple test set operation

## Miscellaneous compatibility upgrades

- **83601A** for 8510C with 83621/31A shipped prior to January 1, 1991  
Includes on-site installation by Agilent Customer Engineer.

## Connector repair kits

Include tools for removing and replacing center conductor contacts of precision slotless connectors (PSC). Kits include ten replacement center conductor contacts.

- **85052-60049 PSC-3.5 connector repair kit**
- **85054-60056 PSC-N connector repair kit**

## User training courses

- **8510C+24D basic measurements using the 8510**  
Three-day user training course. This basic measurements course is recommended to bring you up to speed with hands-on knowledge of the 8510C network analyzer's full capabilities.
- **85101B+24D advanced programming course for the 8510A/B/C**  
Two-day training course on advanced programming topics using BASIC. Prior attendance in 8510B+24D training course is recommended.

## System installation

To include system installation by an Agilent Customer Engineer, order support Option +17A for each major system component (network analyzer, test sets and sources). Installation includes integration of system components and performance verification.

## System performance verification

Recommended once per year. For on-site system performance verification, order Option +23R for each major system component (network analyzer, test sets and sources). Compliance with MIL-STD 45662A is an additional charge (where available).

## **Related Agilent literature**

- 5965-8837E     *8510 System Solutions Brochure*
- 5091-8484E     *8510 Family Network Analyzer  
Data Sheet*
- 5091-8969E     *8510 Performance Upgrades to  
Meet Your New Design and Test  
Challenges - Product Overview*
- 5964-4229E     *85106C Millimeter-Wave Network  
Analyzer System Product Overview*
- 5091-8965E     *85108A/L CW/Pulsed Network  
Analyzer Systems Product  
Overview*
- 5965-9888E     *8510XF Vector Network Analyzer  
Single-Connection, Single-Sweep  
Systems Product Overview*

### **Agilent Technologies' Test and Measurement Support, Services, and Assistance**

Agilent Technologies aims to maximize the value you receive, while minimizing your risk and problems. We strive to ensure that you get the test and measurement capabilities you paid for and obtain the support you need. Our extensive support resources and services can help you choose the right Agilent products for your applications and apply them successfully. Every instrument and system we sell has a global warranty. Support is available for at least five years beyond the production life of the product. Two concepts underlie Agilent's overall support policy: "Our Promise" and "Your Advantage."

#### **Our Promise**

Our Promise means your Agilent test and measurement equipment will meet its advertised performance and functionality. When you are choosing new equipment, we will help you with product information, including realistic performance specifications and practical recommendations from experienced test engineers. When you use Agilent equipment, we can verify that it works properly, help with product operation, and provide basic measurement assistance for the use of specified capabilities, at no extra cost upon request. Many self-help tools are available.

#### **Your Advantage**

Your Advantage means that Agilent offers a wide range of additional expert test and measurement services, which you can purchase according to your unique technical and business needs. Solve problems efficiently and gain a competitive edge by contracting with us for calibration, extra-cost upgrades, out-of-warranty repairs, and on-site education and training, as well as design, system integration, project management, and other professional engineering services. Experienced Agilent engineers and technicians worldwide can help you maximize your productivity, optimize the return on investment of your Agilent instruments and systems, and obtain dependable measurement accuracy for the life of those products.

**By internet, phone, or fax, get assistance with all your test & measurement needs**

**Online assistance:**

**[www.agilent.com/find/assist](http://www.agilent.com/find/assist)**

**Phone or Fax**

**United States:**

(tel) 1 800 452 4844

**Canada:**

(tel) 1 877 894 4414

(fax) (905) 282 6495

**China:**

(tel) 800 810 0189

(fax) 1 0800 650 0121

**Europe:**

(tel) (31 20) 547 2323

(fax) (31 20) 547 2390

**Japan:**

(tel) (81) 426 56 7832

(fax) (81) 426 56 7840

**Korea:**

(tel) (82 2) 2004 5004

(fax) (82 2) 2004 5115

**Latin America:**

(tel) (305) 269 7500

(fax) (305) 269 7599

**Taiwan:**

(tel) 080 004 7866

(fax) (886 2) 2545 6723

**Other Asia Pacific Countries:**

(tel) (65) 375 8100

(fax) (65) 836 0252

Email: [tm\\_asia@agilent.com](mailto:tm_asia@agilent.com)

**Product specifications and descriptions in this document subject to change without notice.**

**© Agilent Technologies, Inc. 2002**

**Printed in USA April 1, 2002**

**5091-8967E**



### **Agilent Email Updates**

[www.agilent.com/find/emailupdates](http://www.agilent.com/find/emailupdates)

Get the latest information on the products and applications you select.

