

B: Ch 1 Spectrum

400MHz

100MHz

Stop

Range: -15dBm

10dB

MEASUREMENT TIPS

Volume 1, Number 3

LogMag

15 dB/div

-165 dBm

Center RBW

Hints for Selecting the Correct Temperature Sensor for Your Application

Ch 15

Ch 16

Ch 1

Span: 12.5 MHz
TimeLen: 3.000375 mSec

USING THE APPROPRIATE SENSORS

Snapshot: Temperature Profiling in Consumer White Goods

If you want to make reliable temperature measurements, you need to carefully select the right temperature sensor for your application. Understanding the advantages and disadvantages of temperature sensors will help you take the proper precautions when you set up a test. Thermocouples, thermistors, resistance temperature detectors (RTDs), and temperature ICs are the most common temperature sensors used in electronic test. This measurement brief compares operating ranges, accuracy, cost, stability, sensitivity and ease of use for these popular temperature sensors.

A manufacturer of high-end home refrigerators wanted to create a 3-D profile of the temperature variations inside its refrigerators. The temperature profile would allow the company to verify the accuracy and consistency of its refrigerators' internal temperature and also allow them to market temperature consistency as a valuable consumer benefit. The manufacturer chose to use Agilent 34970A data acquisition units to conduct the tests. Company test engineers then needed to select the best temperature sensors for the sensor array they needed to insert into the refrigerated cavity. The temperature range was fairly narrow, but they needed high accuracy over that range. Thermocouples were not accurate enough and thermistors were found unsuitable. Ultimately, using the four-wire resistance measurement technique, they used an array of RTDs because they gave the best accuracy in this application.



Agilent Technologies

Temperature sensors

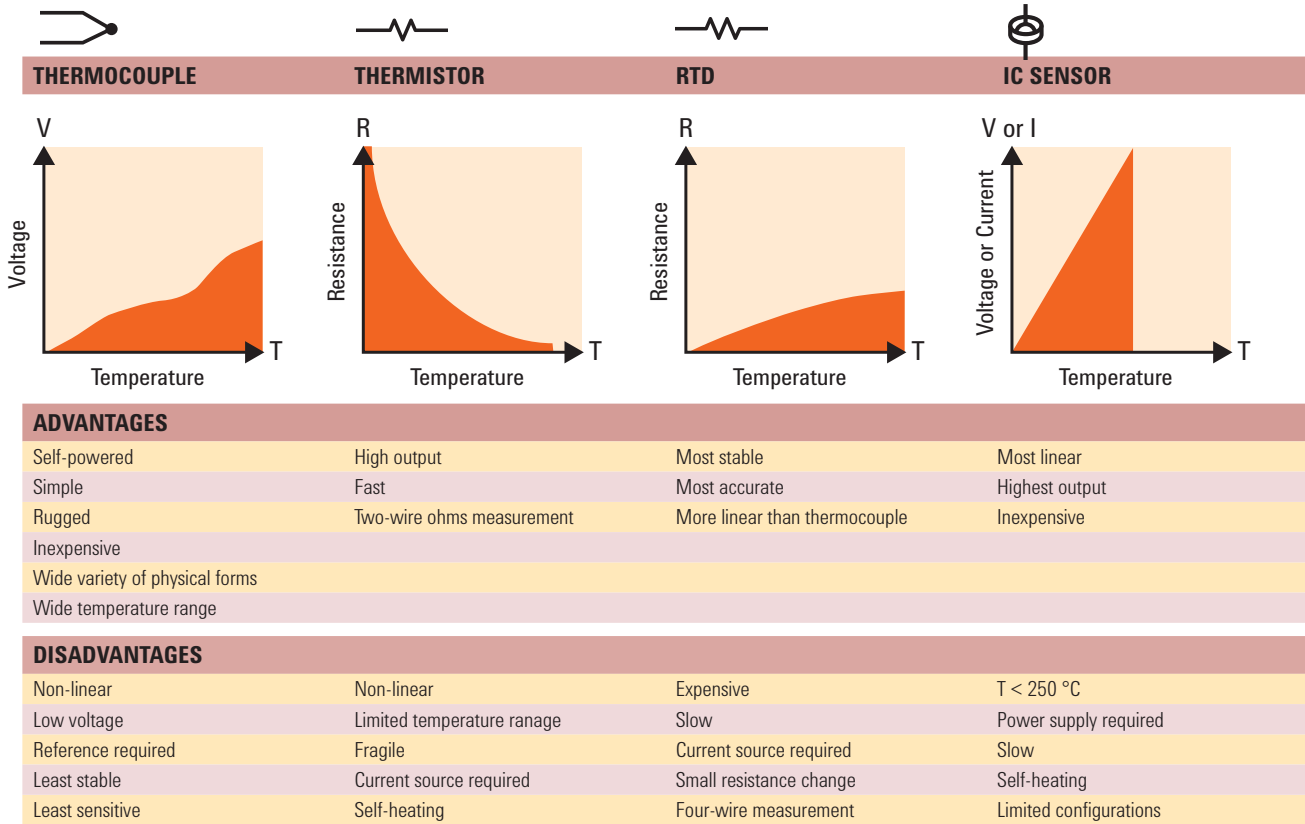

Figure 1: Advantages and disadvantages of popular temperature sensors

Thermocouples



A thermocouple is two wires composed of dissimilar metals (metal A and metal B) that are joined at both ends as shown in Figure 2 below. When one of the ends is heated, a continuous current flows in the thermoelectric circuit. The voltage generated from the temperature gradient is used to calculate the temperature.

Thermocouples are the most common sensors used for temperature measurements. The most important benefit of thermocouples compared to thermistors, RTDs, and integrated circuit transducers is that they can be used over a wide range of temperatures and can be optimized for various atmospheres. They are much more rugged than the alternatives and can be manufactured on the spot, either by soldering or welding. They are also self-powered and are the least expensive of the temperature sensors.

In addition, the relationship between voltage and temperature is non-linear as shown below in Figure 2, and they do not change much with temperature variations. For example, a J-type thermocouple produces 50 μV at 0 $^{\circ}\text{C}$ and changes on the order of 5 μV per $^{\circ}\text{C}$. You need a good measuring device to measure these small voltages. Still, thermocouples are the least sensitive and least stable temperature sensors.

In addition, the relationship between voltage and temperature is non-linear, making it more difficult to convert the measured voltage into temperature. You need a second measurement for the reference temperature (T_{ref}) in order to calculate the thermocouple temperature (T_x). However, modern data loggers process the voltage-to-temperature conversion internally through software and/or hardware, but the extra measurement takes additional time during test.

In short, thermocouples are the simplest and most versatile temperature transducers available, and using a thermocouple becomes as easy as connecting a pair of wires. While these inexpensive transducers are the most commonly used temperature sensors, they may not be suitable for high-accuracy applications.

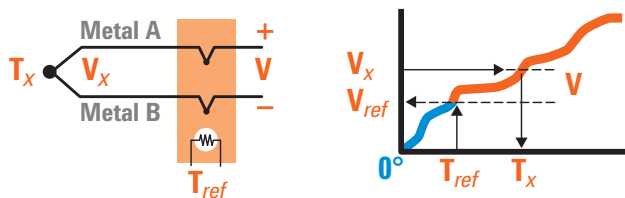

Figure 2: A thermocouple schematic (left) and an example of a voltage vs. temperature curve for thermocouples (right)

Thermistors



A thermistor is a thermally sensitive resistor composed of semiconductor materials, typically ceramic or polymer. Most thermistors have a negative temperature coefficient such that their resistance decreases with an increasing temperature. Thermistors exhibit by far the largest parameter change with temperature and are the most sensitive temperature sensor.

The price we pay for this increased sensitivity is loss of linearity. The thermistor is an extremely non-linear device that is highly dependent upon process parameters. Consequently, manufacturers have not standardized thermistor curves to the extent that thermocouple curves have been standardized.

Thermistors are also very small and respond quickly to temperature changes. However, thermistors require a current source, and their small size also makes them especially susceptible to self-heating errors.

Thermistors offer better accuracy, but are more expensive than thermocouples. They also have smaller temperature ranges than thermocouples. Thermistors measure absolute temperature over a two-wire measurement, whereas thermocouples measure relative temperature between the thermal mass and reference junction. One common type of thermistor has 5 Kohm resistance at 25 °C, and will produce a 200-ohm change for every 1 °C. Note that 10 ohms of lead resistance causes an insignificant error of just 0.05 °C.

Overall, thermistors are most useful in current-controlled applications where you need fast, sensitive temperature measurements. Their small size is beneficial when space is critical, but beware of self-heating errors.

MEASUREMENT TIPS

Thermistors have a small mass, which is good. They settle fast, and won't cause thermal loading. However, they can be fragile due to their size, and a large measurement current will cause self-heating. Since a thermistor is a resistive device, any current source will create power and heat in the thermistor. The amount of power is the square of the current times the resistance. So use a small current source. If a thermistor is exposed to high heat, it will be permanently damaged.

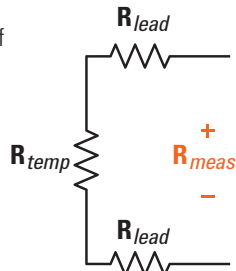

Figure 3: Thermistor schematic

Resistance temperature detectors



Similar to the thermistor, the resistance temperature detector (RTD) is a thermally sensitive resistor composed of semiconductor materials, typically platinum.

When measuring the voltage required to calculate the temperature of the RTD, a DMM uses a known current source and measures the voltage created by the current source. The voltage created by the current source includes the voltage drop on the two leads (V_{lead}) plus the voltage across the RTD (V_{temp}). For example, a common RTD has 100 ohms and changes only 0.385 ohms per °C. If the two leads each had a 10-ohm lead resistance, this would cause a 26 °C error, which is unacceptable. In this case, the voltage drop due to lead resistance (R_{lead}) is unacceptably high. Remember, the same lead resistance caused only a 0.05 °C error with a thermistor. Thus, RTDs need to be measured with 4-wire ohm measurements.

An RTD is the most accurate and stable temperature sensor and is more linear than a thermocouple or thermistor. However, RTDs are the slowest and most expensive temperature sensors. Therefore, they fit precision applications where accuracy is critical while speed and cost are less important.

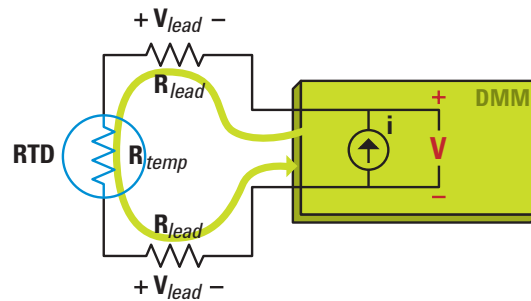

Figure 4: A two-wire RTD measurement

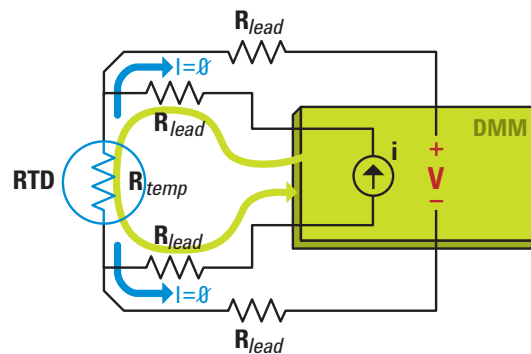

Figure 5: A four-wire RTD measurement

MEASUREMENT TIPS

- Using a 5-mA current source can create a significant temperature error of 2.5 °C due to self heating. Typically, RTDs are used to make accurate measurements. It is important to minimize self-heating errors.
- Four-wire ohm measurements are accurate but require twice the wire and twice the number of switches.

Temperature ICs



Finally, a temperature integrated circuit (IC) is a digital temperature sensor with a very linear voltage- or current-to-temperature relationship. Some integrated sensors even represent temperature in a digital output format that can be read directly by a microprocessor.

There are two types of temperature ICs with the following relationship to temperature:

- Voltage IC: 10 mV/K
- Current IC: 1 μ A/K

Temperature ICs output a very linear voltage per $^{\circ}$ C. The actual voltage produced is per Kelvin, so at room temperature the IC outputs about 3 V. The temperature IC requires an external power source. Typically, temperature ICs are designed into a circuit and are not used for probing.

Except that they offer a very linear output with temperature, these IC sensors share all the disadvantages of thermistors and RTDs. They are semiconductor devices and thus have a limited temperature range. The same problems of self-heating and fragility are evident and they require an external power source.

Overall, temperature ICs provide a convenient way to produce an easy-to-read output that is proportional to temperature. While inexpensive, they are limited in configuration and speed.

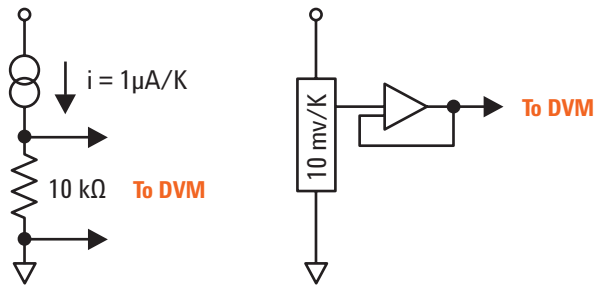

Figure 6: A current sensor (left) and a voltage sensor (right)

MEASUREMENT TIPS

- Temperature ICs are physically large. Because of their large mass, they are slow to change and may cause thermal loading.
- Use temperature ICs near room temperature. This is their most popular application. Although they have a limited range, they can measure up to 150 $^{\circ}$ C.

Summary

We have discussed the advantages and disadvantages of popular types of temperature sensors. If you understand the tradeoffs and carefully select the right temperature sensor for your application, you will be able to make reliable temperature measurements and avoid common pitfalls.



Learn more about the Agilent 34970A (TOP LEFT) data acquisition/switch unit at www.agilent.com/find/34970A

Learn more about the Agilent 34980A multifunction switch measure unit (LOWER RIGHT) at www.agilent.com/find/34980A

www.agilent.com

For more information on Agilent Technologies' products, applications or services, please contact your local Agilent office. The complete list is available at:

www.agilent.com/find/contactus

Product specifications and descriptions in this document subject to change without notice.

© Agilent Technologies, Inc. 2008

Printed in USA, April 16, 2008

5989-7800EN



Agilent Technologies